

**CHARACTERISATION OF CHONDROCYTE
MATRIX RESPONSES UNDER BIAXIAL
LOADING**

ILLIDA BINTI MOHD NAWI

**DISSERTATION SUBMITTED IN FULFILMENT OF
THE REQUIREMENTS FOR THE DEGREE OF
MASTER OF ENGINEERING SCIENCE**

**FACULTY OF ENGINEERING
UNIVERSITY OF MALAYA
KUALA LUMPUR**

2011

Abstract

In vivo, during mechanical loading, articular cartilage is exposed to a complex biophysical environment. These biophysical and biochemical concepts have not yet been fully understood due to intricate combination of direct, shear and tensile compressive strains on articular cartilage. Mechanical forces and deformations are sensed by cells and turned into biochemical signals; which evolution is essential in regulating chondrocyte function; both in metabolic and catabolic *modus operandi*. The main objective of this study is to investigate the influence of biaxial loading on chondrocytes. This thesis will also describe the strain rate influence of biaxial loading on chondrocytes in 3D agarose scaffold in different types of waveform. Prior to the core studies, an optimized protocol to harvest the highest numbers of viable cells was obtained. These allow the preparation of a sufficient quantity of cells for high seeding density, which in turn promotes the expression of normal chondrocytic phenotype and facilitates cartilage repair. This study modulated parameters such as collagenase type, enzymatic duration and collagenases' concentration in order to obtain the highest cell yield and viability. From this study, maximum cell yield was harvested from the two-step digestion with 1-hour digestion of protease and 16-hour in collagenase type-II, without jeopardizing their viability. Cell yield obtained with this protocol was 14 million cells per ml ($\pm 0.41\%$ SEM) and cell viability of 97.5% ($\pm 0.19\%$ SEM).

Consequently, obtained chondrocytes were seeded in 4% three-dimensional agarose constructs. Seeded constructs were exposed to cyclic loading of 10% direct compressive and/nor 1% shear strain(s) to see the effect of biaxial and uniaxial loadings. A novel-designed bioreactor was used to deliver the loads. The load was delivered for two 12

hours-blocks, at a frequency of 1Hz, with 12 hours resting period in the middle. The incubator-housed bioreactor is used to give various types of waveforms to the constructs. The suspension was analyzed for DNA content using Hoechst 33258 dye with calf thymus DNA as a standard. GAG was measured with DMB assays and chondroitin-4-sulphate was used as the reference solution. The need for pre-culturing before exposure to biaxial loading was also examined. Predominantly, chondrocytes favoured to be pre-cultured for 24 hours upon seeding before being subjected to any load and prefer biaxial loading to increase GAG levels. Biaxial loading shows stimulatory effect on matrix synthesis with 1.5-fold increase in GAG production of chondrocytes upon being exposed to biaxial loading vs. uniaxial loading. Nevertheless, chondrocytes seem to favour for sinusoidal loading when it comes to proteoglycans synthesis.

This study has moved research into the effects of mechanical loading on cartilage regeneration a step forward. Due to the complex structure of cartilage – anisotropy and heterogeneity, articular cartilage subjected to mechanical loading has been shown to activate multiple regulatory pathways; upstream signalling, transcription, post-translational modification and vesicular transport. Mechanical loading such as simultaneous matrix stretch and compression facilitates transportation of molecules and nutrients. Signalling mechanisms due to cyclic loading involve the actin cytoskeleton, stretch-activated ion channels and activation of tyrosine kinase.

Abstrak

In vivo, tulang rawan sendi terdedah kepada persekitaran biofizik yang kompleks sepanjang beban mekanikal. Konsep biokimia dan biofizik ini belum difahami sepenuhnya kerana kombinasi rumit antara tekanan langsung, luncuran dan ketegangan pada tulang rawan artikular. Daya mekanik dan deformasi ini dialami oleh sel-sel dan diubah menjadi isyarat-isyarat biokimia. Evolusi ini sangat penting dalam mengawal fungsi sel kondrosit, baik dalam modus operandi katabolik mahupun metabolik. Tujuan utama penyelidikan ini adalah untuk melihat pengaruh beban biaksial terhadap kondrosit. Tesis ini juga akan menjelaskan tahap pengaruh regangan pembebanan biaksial dalam pelbagai bentuk gelombang pada kondrosit dalam skafold 3D *agarose*. Sebelum kajian tersebut, suatu protokol bagi mengoptimumkan tuai angka sel yang hidup tertinggi diperoleh. Dengan adanya protokol ini, bilangan sel yang banyak akan membolehkan adanya jumlah sel yang cukup untuk kultur kepadatan sel yang tinggi, yang kemudiannya akan memupuk ekspresi fenotip *chondrocytic* yang normal dan membantu proses pembaikan tulang rawan. Penyelidikan ini dimodulasi oleh beberapa parameter seperti jenis enzim kolagenase, tempoh pendedahan terhadap enzim dan konsentrasi kolagenase untuk mendapatkan bilangan sel yang tertinggi dan peratusan sel hidup. Dari kajian ini, bilangan sel maksimum dituai daripada pencernaan dwi-langkah dengan 1 jam pencernaan menggunakan enzim protease dan 16 jam dalam kolagenase-II, tanpa mengorbankan tahap peratusan sel hidup. Bilangan sel diperolehi dengan menggunakan protokol ini adalah 14 juta sel per ml ($\pm 0.41\%$ SEM) dan sel hidup sebanyak 97.5% ($\pm 0.19\%$ SEM).

Seterusnya, kondrosit yang diperolehi dikultur dalam skafold tiga dimensi yang diperbuat daripada 4% *agarose*. Skafold yang mengandungi kondrosit didedahkan kepada beban siklik yang terdiri daripada tekanan langsung sebanyak 10% dan / tanpa regangan luncuran sebanyak 1% untuk melihat pengaruh beban uniaksial dan biaksial. Bioreaktor rekaan nobel digunakan untuk memberikan beban. Muatan diberikan selama dua blok 48 jam, pada frekuensi 1 Hz (12 jam beban: 12 jam tanpa beban). Bioreaktor yang ditempatkan di dalam inkubator ini, digunakan untuk memberikan pelbagai jenis bentuk gelombang terhadap sel. Suspensi sel kemudiannya dianalisa untuk kandungan DNA menggunakan pewarna Hoechst 33258 dengan *thymus* DNA anak lembu digunakan sebagai standard. GAG diukur dengan ujian DMB dan *chondroitin-4-sulfat* digunakan sebagai rujukan. Selain itu, keperluan pra-kultur selama 24 jam selepas pencampuran sel sebelum didedahkan kepada beban biaksial juga diperiksa. Secara dominan, pra-dikultur sel selama 24 jam selepas dimasukkan ke dalam skafold kepada kondrosit sebelum dikenakan beban lebih memberi kebaikan. Kondrosit juga lebih menjurus kepada beban biaksial untuk peningkatan tahap GAG yang optimum. Beban biaksial menunjukkan kesan stimulasi pada sintesis matriks dengan kenaikan 1.5 kali ganda dalam produksi GAG oleh kondrosit yang mengalami beban biaksial berbanding uniaksial. Selain dari itu, kondrosit menunjukkan advokasi terhadap pembebanan secara sinusoidal untuk sintesis proteoglycan yang lebih maksimum.

Penyelidikan ini telah membawa kajian kesan pembebanan mekanik pada regenerasi tulang rawan setapak ke hadapan. Oleh kerana struktur kompleks tulang rawan yang anisotropik dan heterogenitas, beban mekanikal yang dialami tulang rawan telah mengaktifkan beberapa percaturan; yakni isyarat pertambahan, transkripsi, pengubahsuaian pasca-translasi dan pengangkutan vesikuler. Beban mekanikal seperti

peregangan matriks serentak dengan mampatan membantu pengangkutan molekul dan nutrisi. Mekanisma penghantaran isyarat akibat beban siklik melibatkan sitoskeleton aktin, ion saluran aktif regangan dan pengaktifan kinase tirosin.

Acknowledgement

I would like to show my heartfelt thanks and appreciation to my supervisor Dr. Belinda Murphy. She has made available her supports in a number of ways, including the times when she told me to get out from her lab and move forward. It is her encouragement, supervision and support from the preliminary to the concluding level enabled me to develop an understanding of the research. I would also like to thank Mr. Vincent Murphy, for relentlessly giving suggestion when I was stuck in the middle of the project.

I also owe my deepest gratitude to my husband who has been helpful and understanding throughout the process of this project. He has been struggling to balance between listening to me nagging about this project, taking care of our son and helping with the house chores.

This thesis is especially dedicated to my 3-year old son who had to stay at the childcare centre until late night, waiting for me finishing up my lab work. I am deeply sorry for the time we spent apart.

I would also like to show my gratitude to my father who constantly calling and reminding me of my datelines. He has also provided me with necessary assistance with my data analysis.

Thanks to Mr. John Temesi who proofread my thesis and million thanks to the lab technician, Mr. Adhli Iskandar, my colleagues, and lab mates.

Last but surely not the least, my deepest appreciation to my family for always being there cheering me up and stood by me through the good and bad times.

Table of Contents

Abstract	ii
Abstrak	iv
Acknowledgement.....	vii
Table of Contents	viii
List of Figures	x
List of Tables.....	xvi
List of Symbols and Abbreviations.....	xviii
Chapter 1. Introduction	1
1.1. Tissue Engineering.....	1
Thesis Structure.....	6
1.2. Aims and Objectives	6
Chapter 2. Literature Review	8
2.1. Cartilage	9
2.2. Chondrocytes	21
2.3. Tissue Engineering of Cartilage.....	26
2.4. Mechanotransduction	28
Chapter 3. Methodology	39
3.1. Methods in Cell Isolation.....	39
3.2. Methods in Culture Preparation	45
3.3. Methods in Biomechanical Stimulation.....	50
3.4. Biochemical Assays	53
3.5. Statistical Analysis	58
Chapter 4. Study 1 (Chondrocyte Isolation)	59
4.1. Introduction.....	59

4.2.	Methods.....	60
4.3.	Results.....	61
4.4.	Discussion	65
Chapter 5.	Study 2 (Effects of Dynamic Uniaxial Loading on Cellularity and ECM Production) 69	
5.1.	Introduction.....	69
5.2.	Methods.....	70
5.3.	Results.....	71
5.4.	Discussion	74
Chapter 6.	Study 3 (Effects of Dynamic Biaxial Loading on Cellularity and ECM Production) 77	
6.1.	Introduction.....	77
6.2.	Methods.....	78
6.3.	Results.....	79
6.4.	Discussion	82
Chapter 7.	Discussion	84
7.1.	Introduction.....	84
7.2.	Is biaxial loading beneficial to the metabolic response of chondrocytes? 84	
7.3.	Is Pre-Culture Advantageous To The Chondrocyte Response?.....	92
7.4.	General Data Analysis	101
7.5.	Experimental System	108
Chapter 8.	Conclusion.....	114
8.1.	Introduction.....	114
8.2.	Possible Mechanotransduction Pathways	114
8.3.	Future Work and Recommendation	117
References	120	

List of Figures

- Figure 2.1 Collagen fibril and triple helix tropocollagen. (a-c) Repeating disaccharides building an amino acid sequence called precursor that coils left-handedly to form a triple helix. (d) The propeptides cleaved together to form collagen fibrils. The distance between the “head” (↑) and the “tail” (•) of the next collagen molecule is constantly about 67nm. This constant value is important for the collagen fibrils to produce a structured formation called “staggered-array”. The interactions between parallel groups are moderated by covalent bonds. (e) Bunch of collagen fibrils are densely-packed forming collagen fibrils. Adapted from Lodish, Berk et al. (2000) and Massachusetts Institute of Technology (2006).12**
- Figure 2.2 Zonal arrangement of fibrillar architecture. From outermost (contact with AC) to innermost (next to subchondral bone): superficial zone, middle zone, deep zone and calcified zone. Adapted from Mow, Fithian et al. (1990).....13**
- Figure 2.3 Brush-bottle-like structure of proteoglycan. Adapted from Iozzo (2000).....15**
- Figure 2.4 Aggrecan attached to hyaluronic acid (HA). N-terminal of G₁ domain binds to HA, G₂ is the second globular region, and G₃ is the C-terminal domain of aggrecan. IG stands for the immunoglobulin domain. Adapted from Kiani, Chen et al. (2002) and Paulsson, Morgelin et al. (1987).15**
- Figure 2.5 The immunoglobulin protein at the G₁ region contains two heavy and two light chains. The hyaluronic acid interacts to aggrecan through the disulphide bonds. Adapted from Brown (2002).16**
- Figure 2.6 Three regions that are identified that enveloped the chondrocytes; pericellular, territorial and interterritorial. Adapted from Alberts, Bray et al. (1998).19**
- Figure 2.7 Schematic diagram of cytoskeleton during mechanotransduction. Upon experiencing shear stress, stretch and pressure; certain mechanosensors at the cytoskeleton will transmit signals that concurrently inevitable to initiate cells’ regulations.33**
- Figure 3.1 Exposure of articular surfaces from a metacarpal-phalangeal joint.44**
- Figure 3.2 Figures showing assembly of the Perspex mould. The perspex mould is comprised of base (a), mould divider and lid. (b) Sintered glass strips were inserted into the slot of mould**

divider. (c) Once the chondrocyte-agarose suspension was pipette in the voids, the lid was screwed to avoid bubble formation. The mould is used to attach the agarose-chondrocyte constructs to the sintered glass strips.47

Figure 3.3 Photo of the plated constructs structure inside the culture tray. Arrow showed the sintered glass strips attached to the shear and compressive brackets with six samples of chondrocyte-agarose constructs sandwich between the sintered glass.....48

Figure 3.4 Upon lifting up the lid and mould divider, the sintered glass strips are attached to the shear and compressive brackets. Custom-made handle is then used to transfer the brackets to the test rig.48

Figure 3.5 Schematic drawing of Perspex mould to produce agarose-chondrocyte-sintered glass constructs. (a) Mould divider attached to the base and (b) chondrocyte-agarose suspension pipette in the voids and was covered with lid. The specimens were then put into a 6-well plate filled with culture medium. These specimens were then tested as the control or free-swelling samples.....50

Figure 3.6 The schematic representation of the configuration of the incubator-housed and PLC-controlled cartilage bioreactor system: A – Standard incubator; B – Culture tray; C – Peristaltic pump; D – Medium reservoir; E – Medium inlet and outlet ports; F – Stepper motors; G – PLC control box; H – Stepper motor drivers; I – Power supply. (Yusoff, 2011) .51

Figure 3.7 Once the agarose-chondrocyte constructs were transferred to the test rig, SS columns were fixed to the direct and shear compressive brackets upon removal of the handle. These steps need to be done carefully to avoid any movement of the constructs.52

Figure 3.8 Culture medium was poured into the test rig, making sure all constructs were fully immersed. Prior to the transportation of test rig into the incubator, the rig was covered with a lid to ensure sterility. Bug filter was integrated to the test rig making sure of gas exchange going in and out of the test rig.52

Figure 4.1 a) Cell yield with different types of collagenase. (*) denotes significantly different ($p < 0.05$) cell yield versus all types of collagenases. (b) Cell viability with different types of collagenase. (*) denotes cell viability with significantly different $p < 0.05$ versus collagenase

Type Ia, while the difference of cell viability collagenase Type II and Type XI is insignificant.

All values shown as mean \pm standard error of the mean (SEM) (n=30).63

Figure 4.2 (a) showing cell yield from digestion using concentration of either 100 or 200 U.ml⁻¹.

Higher concentration produced significantly higher cell yield. Cell viability for cells using reduced concentration has shown a significant decrease (b). (*) shows significant value of (p<0.05) by ANOVA and error bars showing standard error of the mean.....64

Figure 4.3 Influence of digestion time on cell yield (a) and cell viability (b). (*) indicates that single-

factor ANOVA test shows that cell yield and cell viability of 16 hours versus 15 hours and 14 hours is highly significant (p<0.05). All values shown are mean values for n=30. Error bars represent standard error of the mean.64

Figure 5.1 The percentage change from unstrained control values for a) DNA content and b) GAG

content in chondrocyte-agarose digest upon subjected to 10% gross compressive strain in trapezoidal and sinusoidal waveform for 48 hours. Each value represents the mean and standard error of 24 replicates, normalised to the control unstrained samples (100%). One-way ANOVA indicate differences between trapezoidal, sinusoidal and unstrained control samples as (*)p<0.05.....73

Figure 5.2 Evaluation of the 24 hours pre-culture effect on a) DNA content and b) proteoglycan

production by chondrocytes encapsulated in agarose scaffolds. Upon seeding, the chondrocytes-agarose constructs were left free swelling within the incubator for 24 hours, before being exposed to dynamic 10% direct compressive strain for 48 hours. Data are given by mean and standard error of mean (n=24) with (*)p<0.05. The data are normalised to the control unstrained specimens to eliminate other independent variables.74

Figure 6.1 (a) Cell proliferation and (b) proteoglycan synthesis by chondrocytes seeded in agarose

scaffold upon being loaded to trapezoidal or sinusoidal biaxial strain at magnitude of 10% direct and 1% shear compressive strain. Error bars represent means and SEM of 24 replicates, normalised to the control unstrained samples (100%). (*) showing highly significant values across the loading factor (p<0.05).81

Figure 6.2 Upon free swelling pre-culture for 24 hours, the chondrocyte-agarose constructs were

loaded in a biaxial manner. At the end of the experiment, DNA content (a) and proteoglycans

synthesis (b) were quantified. The values are depicted as means and standard error. The values were normalised to unstrained samples as the control group. Two-way ANOVA test has shown that all data were significant to among those samples loaded under either trapezoidal, sinusoidal or even unstrained. (*) $p < 0.05$81

Figure 7.1 The effect of uniaxial and biaxial loading on chondrocytes when cultured under compressive strain on cell proliferation and proteoglycan production. These data are normalised to the respective control unstrained samples (100%) to eliminate other uncontrollable variables. Each data is reported as mean and standard error (n=24) with (*) $p < 0.05$86

Figure 7.2 Interaction effect found to be significant in proteoglycans production (b), but not in DNA content (a). This cross effect have shown that two factors (uniaxial/biaxial) and loading waveforms contribute to higher production of proteoglycans, (*) $p < 0.05$88

Figure 7.3 The effect of dynamic compression either by uniaxial or biaxial loading at different waveform on the DNA content (a) and proteoglycan synthesis (b), shown as percentage, normalised to the values of unstrained control group (100%- not shown in graph). The specimens were pre-cultured under free-swelling for 24 hours prior to being subjected to loading. Total number of samples involved was 24 samples for each condition and tests were replicated in separate weekly experiment. (*) $p < 0.05$90

Figure 7.4 Interaction effect found to be significant in DNA content (a) and proteoglycans production (b). This cross effect have shown that two factors (uniaxial/biaxial) and loading waveforms contribute to higher production of proteoglycans, (*) $p < 0.05$91

Figure 7.5 Trapezoidal and sinusoidal uniaxial strained constructs measured (a) DNA content normalised to control NPC unstrained specimens (100%) and (b) proteoglycans synthesis, also normalised to control NPC unstrained samples (100%). In both DNA and GAG level, pre-cultured (PC) samples seem to have advantages over the non-pre-cultured (NPC) ones. 24 hours pre-culturing significantly increase DNA content and proteoglycans production in all three cases (trapezoidal, sinusoidal and unstrained). (*) $p < 0.05$, while (**) also indicates $p < 0.05$ for all loading conditions.....95

Figure 7.6 Line graphs showing interaction effect for DNA content (a) and GAG production (b). No interaction can be seen for DNA content between NPC and PC samples ($p > 0.05$). The graph shows that there are cross effect for GAG production between non pre-cultured (NPC) and pre-cultured (PC) specimens, suggesting that the results of GAG production depends on pre-culturing factor and loading factor. (*) signifies $p < 0.05$96

Figure 7.7 A trend of biaxial loading waveforms from the least to the most significant in terms of producing stimulation effect on chondrocytes to proteoglycans synthesis.98

Figure 7.8 Data were collected to see the effect of (a) DNA content, normalised to the unstrained samples as the control group (100%) and (b) proteoglycan production by chondrocytes seeded in agarose loaded in biaxial manner immediately after cell seeding or upon 24 hours pre-culture under free-swelling condition. The data were taken from a total of 72 samples for each pre-cultured (PC) and non pre-cultured (NPC) conditions. (*) $p < 0.05$, while (**) also indicates $p < 0.05$ for PC samples versus NPC samples in all loading conditions.99

Figure 7.9 Interaction effect of non pre-cultured and pre-cultured specimens in terms of a) DNA content and b) chondroitin sulphate incorporation using DNA content as the baseline. Graphs show that cross effect can be seen from the level of proteoglycan synthesis (* signifies $p < 0.05$), but no cross effect for DNA content ($p > 0.05$). 100

Figure 7.10 DNA level measured from digested constructs that were either loaded trapezoidal/sinusoidal or were left unstrained as the control group (100%- not shown in graph). The loading regime was set to 10% direct and/nor 1% shear compressive strains. Half of the agarose constructs were directly subjected to load upon seeding with chondrocytes, while the other half were pre-cultured for 24 hours prior to be subjected to load. Data were tabulated from 24 samples for each condition and each data was normalised to control unstrained groups. (*) $p < 0.05$. As a sum, uniaxial gives higher effect on DNA content regardless of loading waveforms ($p < 0.05$). 102

Figure 7.11 GAG content is assessed from all samples loaded either uniaxial or biaxial (trapezoidal/sinusoidal) as well as the control unstrained groups (100% - not shown in graph). Both non pre-cultured (NPC) and pre-cultured (PC) samples are also taken into account. The data comes from the same number of replicates for each case, $n=24$. Data from each case were

shown to be highly significant for (*) where $p < 0.05$. In a sum, biaxial gives stimulatory effect to GAG production ($p < 0.05$)..... 103

List of Tables

Table 2.1 Mechanical properties of articular cartilage. Adapted from Mow et al. (1990).	21
Table 2.2 List of functions for each organelle found in chondrocytes. Adapted from Minuth, Strehl et al. (2005) and Scheffler (1999).	22
Table 2.3 Summary of studies that have been done to assess response of cartilage to mechanical load <i>in-vitro</i>	35
Table 3.1 Summary of comparisons made between the different enzymatic digestion protocols, showing enzymes used, their concentrations and digestion times.	40
Table 3.2 Components of Chondrocyte Medium.....	42
Table 3.3 Types of Collagenase and Concentration used during the experimental work.....	44
Table 3.4 Layout of the microplate. S wells are filled with chondroitin-4 sulfate at stated concentration, while X wells are filled with samples. All wells including the blank ones are filled with DMB assay.	57
Table 4.1 Optimized chondrocyte isolation protocol.....	65
Table 5.1 Absolute values for GAG content in medium, constructs and total GAG synthesis, with DNA content as baselines by chondrocyte/agarose constructs subjected to various waveform uniaxial loading. The average values are taken from 24 samples from four separate experiments. Errors shown are standard error of mean.	71
Table 6.1 Absolute values for GAG content in medium, constructs and total GAG synthesis, with DNA content as baselines by chondrocyte/agarose constructs subjected to various waveform biaxial loading. The average values are taken from 24 samples from four separate experiments.	79
Table 6.2 Absolute values for GAG content in medium, constructs and total GAG synthesis, with DNA content as baselines by chondrocyte/agarose constructs subjected to various waveform biaxial loading. The average values are taken from 24 samples from four separate experiments. All samples were pre-cultured for 24 hours before loading.	80
Table 7.1 Proteoglycan levels detected in medium and in digested constructs upon being exposed to compressive and/nor shear strain.	87

Table 7.2 Mean of DNA content and proteoglycan synthesis, as a total of trapezoidal, uniaxial and unstrained uniaxial or biaxial loading. Values shown are means and SEM of 24 replicates in four separate experiments. Otherwise stated by ^{ns} showing insignificant comparison, values are significant with $p < 0.05$87

Table 7.3 Loading regime that shows stimulation effect to increase DNA content and proteoglycan synthesis in both uniaxial and biaxial cases. Data is based on values which represent means \pm SEM. () $p < 0.05$87**

Table 7.4 Mean value of all 24 samples from biaxial and uniaxial loading. The samples were put to free-swelling for the first 24 hours before subjected to loading. All values are normalised to the control unstrained group and a two-way ANOVA has given p value of less than 0.05(), suggesting significant values for all measurements at all conditions.....91**

Table 7.5 Loading regime that shows stimulation effect to increase DNA content and proteoglycan synthesis in both uniaxial and biaxial cases. () $p < 0.05$91**

Table 7.6 Mean values of DNA content, GAGs measured in medium and in constructs of non pre-cultured (NPC) and pre cultured (PC) specimens for all loading conditions. There were about 24 samples for each case. DNA levels were used as the baseline for proteoglycan synthesis measurement. Values shown as mean \pm SEM. Unless stated, ** shows p value of less than 0.05 between NPC and PC samples.94

Table 7.7 Mean values for GAG in medium, constructs and DNA content in all samples (n=72) for non pre-cultured (NPC) group and pre-cultured (PC) group. It is shown that PC has a significant effect on $GAG_{\text{Medium}}/\text{DNA}$ and DNA content () $p < 0.05$98**

Table 7.8 Analysis of combination of all factors, non pre-cultured (NPC)/ pre-cultured (PC) and loading regimes, using a three-factor ANOVA using SPSS. Equal replications of 24 samples for all conditions were used to tabulate these data. () $p < 0.05$104**

List of Symbols and Abbreviations

Analysis of Variance	ANOVA
Articular Cartilage	AC
Dimethylmethylene blue	DMB
Dulbecco's Modified Eagles Medium	DMEM
Earl's Balanced Salt Solution	EBSS
Endoplasmic Reticulum	ER
Extracellular Matrix	ECM
Fetal Bovine Serum	FBS
Glycosaminoglycan	GAG
Growth Factor	GF
Hyaluronic Acid	HA
Immunoglobulin	IG
Intermediate Filament	IF
Mesenchymal Progenitor Cell	MPC
Mesenchymal Stem Cell	MSC
Microfilament	MF
Microtubule	MT
Nitric Oxide	NO
Non Pre-Cultured	NPC
Osteoarthritis	OA
Polyethylene	PE
Polyglycolic Acid	PGA
Pre-cultured	PC
Programmable Logic Controller	PLC

Proteoglycan	PG
Stainless Steel	SS
Tissue Engineering	TE

Chapter 1. Introduction

1.1. Tissue Engineering

The aspiration of having human organs to ready order and so putting an end to organ transplant waiting lists has given rise to high hope in tissue engineering. An interesting research project by Dr. Charles Vacanti at the laboratory of University of Massachusetts Medical Centre involved growing a human ear on the back of a mouse. Teams of researchers throughout the world have managed to produce new pulmonary arteries, jaw bones and teeth (Meyer, 2009; Parry, 2005). Tissue engineering has become a very promising biomedical technology.

Tissue engineering is the evolution of biological substitutes through the use of living cells and materials of synthetic or natural origin, and the fostering of tissue regeneration and remodelling. The objective of multi-disciplinary tissue engineering is to restore tissue structure and function that is lost due to trauma, diseases or hereditary abnormalities. Three main components of tissue engineering are cells, matrix and signalling molecules (Yang & Elisseeff, 2007).

In tissue engineering, cells are the architects of all types of tissues. Tissue engineering approaches are initiated by acquiring large numbers of cells from tissues. Cells are the biological sources of components for the extracellular matrix (ECM) (Muir, 1995). The potential availability of primary cells that can be implanted at the impaired regions is very limited due to immunological rejection. While immunosuppressive drugs or autologous cells can be used to solve the rejection problem, long term results remain unsatisfactory (M. Buschmann, Gluzband,

Grodzinsky, & Hunziker, 1995; Estes, Gimble, & Guilak, 2004; McMahon, Reid, Campbell, & Prendergast, 2008). Besides primary cells, multipotent progenitor cells such as mesenchymal stem cells and embryonic stem cells are also capable of differentiating into connective tissue cells (Yang & Elisseeff, 2007).

Cells alter their internal forces when a change in external loading is sensed. It is believed that this mechanism has a role in regulating cell functioning, growth and remodelling. Studies have shown that mechanical stimuli are capable of initiating biochemical signalling (Michael D. Buschmann et al., 1999; Y. Kim, Bonassar, & Grodzinsky, 1995; Seidel et al., 2004; Shiu, 2007; Waldman, Spiteri, Grynepas, Pilliar, & Kandel, 2004).

Signalling molecules can also be triggered by growth factors (GFs). Insulin like growth factors (IGFs), fibroblast growth factors (FGFs) and platelet-derived growth factors (PDGFs) are some of the growth factors used in tissue engineering. Initially, GFs were injected directly into the tissues. However, this method is unfavourable since GFs have very short half-lives in vivo. Encapsulation of GFs into scaffold results in stabilization of GFs in the matrix and controlled release of GFs into the cell microenvironment (Farach-Carson, Wagner, & Kiick, 2007).

Besides cells and signalling molecules, a scaffold that works as temporary matrix is also essential. Cell-seeded scaffolds act as structural supports for cells at the primitive stage of tissue development, both in terms of promoting desired phenotype and regeneration of cartilage. Cells attach to the matrix of the scaffold temporarily and the matrix eventually degrades to provide more space for the newly synthesized ECM. Besides being biodegradable, a three dimensional scaffold must also be non-toxic,

biocompatible and non-immunogenic. Higher porosity of the scaffold results in better nutrient and waste diffusion into the scaffold and cells (Yang & Elisseeff, 2007).

Both natural and synthetic polymers can be used as scaffolds. Used individually or in combination, their selection depends on the purpose, location and type of cells. Natural polymers such as collagens and hyaluronan are widely used as these two components are found in cells, besides agarose and alginate that are widely used in most studies (Chai, Arner, Griggs, & Grodzinsky, 2010; Kock et al., 2009; R. M. Schulz, Wustneck, Donkelaar, Shelton, & Bader, 2008; Zeiter, der Werf, & Ito, 2009). Synthetic polymers such as polylactic acid (PLA), polyglycolic acid (PGA) and polylactic-co-glycolic acid have shown positive results when seeded with cells (Agrawal & Ray, 2001; Ivan. Martin et al., 2001). Further developments have enhanced the biocompatibility, bioresponsiveness and biodegradability of synthetic polymers (Hern & Hubbell, 1998; Rowley & Mooney, 2002).

1.1.1. Cartilage Tissue Engineering

The reason for the interest in cartilage within the present study emerges from the high prevalence of joint ailments and the difficult there is in treating them effectively. One in ten people worldwide have osteoarthritis, a recurring progressive degenerative disease which is usually caused by trauma or overuse of the joints (Lohmander, 2003). To gain an estimate of the scale of the problem, consider that treatment of arthritis costs the British National Health Service more than £560 million annually, mainly drug and rehabilitation costs (Morse, 2009). Medical costs, when added to lost productivity and a degraded quality of life, make this a major and increasing expense in nations with ageing populations.

Cartilage as a tissue presents some unique challenges for orthopaedic medicine. At the heart of the difficulty is a low turnover and self-repair ability which means that even normal wear-and-tear over a lifetime can overpower the natural repair characteristics of the surface and permit progressive degeneration. Whereas some tissues might be expected to repair when given appropriate support and rest, this is rarely the case for articular cartilage.

Because the root of the problem is an inability to effect natural repair, tissue engineering (TE) is a solution of high potential. The concept of being able to create an environment conducive to effective tissue re-growth and integration by means of a TE strategy theoretically allows for a side-stepping of the ineffective natural repair process.

It will be noted that the two factors which most keenly influence the effectiveness of a TE solution for articular cartilage are the extent to which a functional matrix can be produced and the ability to stimulate and sustain cell proliferation. These are both the product of the signalling strategy, the way in which the cells are manipulated by the sending and triggering of signals such that they respond in the most advantageous manner.

A typical TE strategy for cartilage repair involves functional cartilage grown in-vitro on bioresorbable artificial scaffold, or osteochondral grafts delivered to the defect site (Hyun & Chang, 2000).

1.1.2. Mechanical Load in Cartilage Tissue Engineering

Articular cartilage itself is remarkable for its load-bearing location, being subjected to complex loading patterns which help to define, refine and remodel the tissue.

Mechanical loading is thus a part of the normal physiological environment for articular chondrocytes, and something which is of particular importance to the signalling strategy. That there is a role of mechanical load in cartilage tissue remodelling and chondrocyte signalling has been clearly established (Lucchinetti, Bhargava, & Torzilli, 2004; Macdonald, 2002; J.K. Mouw, Imler, & Levenston, 2007). What remains unanswered is what this role is, and most specifically, the route in which the mechanical environment used within a TE strategy influences matrix synthesis and cell proliferation.

There are a number of ways to investigate this interrelation. One approach is to use methods from cellular physiology to understand the mechanisms used by the cell to sense and respond to mechanical loading. This has brought significant understanding to the field (Wang & Thampatty, 2006), however it is rare for such an approach to produce results directly applicable to a TE strategy. Another important form of research involves engineering optimisation of the process, which takes the form of a structured analysis of the way in which the input parameters influence the output variables. This leads to a practical understanding of the way in which a TE strategy can be designed, optimised and implemented – and both supports and is supported by cellular physiology.

Within this present work, the second of these approaches is to be applied. The differential response of articular cartilage (AC) derived chondrocytes to a progressive optimisation and modification of mechanical loading will be analysed in terms of cell proliferation and matrix synthesis. The work thus aims to bring about a greater level of

understanding such that TE strategies for articular cartilage might be better guided by confirmed results demonstrating what has been shown to bring about optimal results.

Thesis Structure

The work is structured such that the current state of scientific knowledge across the field is reviewed. Following this, the general methods and background theories which support the investigation to follow are described and specific constraints and limitations described.

The experimental work is reported as three successive studies. The first outlines crucial work undertaken in the optimisation of experimental methods, specifically in the isolation of viable articular chondrocytes. The next two studies are a progressive investigation into the response of articular chondrocytes to a variety of loading regimes: the influence of static and dynamic uniaxial loading; the differential effect of biaxial loading; and, the extent to which pre-culture time modulation effects change in output metabolism.

The studies are brought together with a general discussion of the interrelation of results obtained and reflections upon comparable studies from other researchers. The present work ends with a general conclusion which reiterates the points determined through the research study as a whole and points to their applicability both in terms of clinical or research practice, and as a foundation for further investigative studies.

1.2. Aims and Objectives

Physiological loading patterns produced by gait and walking activities comprise a combination of loading forms, varying in terms of approximately equivalent to

frequency, force, waveform and duration, and including a variable mix of static, compressive and shear loading components.

Studies have shown that mechanical stimuli are capable to initiate biochemical signalling, which subsequently direct and mediate both anabolic and catabolic processes. This study is designed to characterize the response of tissue engineered chondrocytes to being exposed to complex biaxial mechanical loading regimes. A correlation between mechanical loading and mechanotransduction through the effect of compression and shear strains on cytoskeleton of chondrocytes will later be explained at the end of this study.

The aim of this study is to see the effect of mechanical stimulation on chondrocytes.

Secondary objectives are:

- To optimize isolation protocols to obtain the highest cell yield and greatest cell viability
- To analyze the reaction of chondrocytes towards dynamic mechanical loading
- To assess the effect of various mechanical loading patterns (uniaxial and biaxial) on chondrocyte proliferation and GAG synthesis, using established biochemical assays.

Chapter 2. Literature Review

In order to properly investigate the chosen topic it is important to have a detailed understanding of the underlying biological and scientific fields. Of particular centrality is cartilage itself, and this is treated first – in terms of its anatomy, physiology, biomechanics and common forms of pathology. The second section focuses upon the chondrocyte, the most prevalent cell within cartilage and the biological entity responsible for cartilage maintenance, repair, turnover and remodelling.

Next, the specific challenge of TE of cartilage is addressed. This involves first a review of forms, methods and results obtained through existing strategies for TE of cartilage. Following this a detailed review section is presented focused upon the specific role of mechanotransduction within cartilage signalling and tissue engineering strategies. Particular attention is given to the contribution of a wide range of investigational techniques to the current state of knowledge regarding this mechanotransduction such that a comprehensive picture is built through the literature review process. The state of current scientific knowledge, and proper consideration of established methodologies and protocols, allows for the study to be well designed and to be focused upon answering questions in such a way that they contribute to the leading edge of research in the field.

2.1. Cartilage

Cartilage is a specialised type of connective tissue that is semi-transparent, flexible and elastic. Like other connective tissues, cartilage consists of cells, collagen fibres and matrix. There are three distinctive types of cartilage; 1) elastic cartilage, 2) fibrocartilage and 3) hyaline cartilage.

The properties of elastic cartilage are a result of the combination of high concentrations of elastin and low density of collagen fibres (Porth, 2007). Microscopically, this yellowish cartilage can be recognized by its chondrons that contain few cells (Gartner, Hiatt, & Strum, 2006). This tissue type is less vulnerable to degenerative changes, due to the perichondrium encircling the elastic cartilage and its location being at non-loading areas such as the epiglottis, the wall of Eustachian tubes and the small bronchi (Porth, 2007). Fibrocartilage, on the other hand, contains longitudinal, circumferential oriented collagen fibres, making it suitable to withstand compression at the intervertebral discs and pelvis. Besides elastic cartilage and fibrocartilage, hyaline cartilage is a type of cartilage that can be found abundantly in human body. During early stages of life, hyaline cartilage forms the embryonic skeleton. Hyaline cartilage inside bones serves as the centre of ossification. A special type of hyaline cartilage, articular cartilage (AC) covers articulating joint surfaces at the ends of long bones (Porth, 2007).

Within this thesis, the focus will be exclusively on AC and references to cartilage which are unqualified should be understood as referring to AC.

2.1.1. Gross Anatomy

Articular cartilage is a glassy, smooth and glistening cartilage that covers the bone at the diarthrodial joints. AC is an inhomogeneous tissue that has a very complex composition and architecture. Being biphasic, 70-80% of its ECM is comprised of water, whilst the solid phase of the ECM contains collagens, proteoglycans (PGs), non-collagenous proteins and glycoproteins. ECM supplies each cell with architectural cues, growth factors, differentiation factors, cytokines and ion gradients (Farach-Carson, Wagner, & Kiick, 2006).

AC minimizes the friction produced between joints at rigid bones and it distributes contact pressure to the subchondral region of the trabecular region. It can be found at the articulating joints such as knee, hip and shoulder. AC with thickness at a range of 2 to 5 mm caps the ends of bone that form synovial joints (Athanasίου, Darling, & Hu, 2009; Shindle, Li, Kelly, & Potter, 2010).

2.1.2. Collagen

An important component that makes up one-third of the total weight of cartilage in humans is collagen. Collagen is an insoluble fibrous protein in the ECM that serves as a framework or internal scaffolding where chondrocytes anchor. The basic structural unit of collagen is a triple helix. Three left-handed coiled precursor polypeptides α -chains, consequent to the huge quantities of proline and glycine, twist together to form a triple helix that coils right-handedly. The triple helix is stabilized by many hydrogen bonds. The amino acid sequences of the triple helix collagen are generally Gly-X-Pro and Gly-X-Hyp. The third residue of the triple helices is glycine. The steric hindrance requires that glycine be the third residue. The interior axis of the helix can only fit the single

functional group of glycine; the hydrogen atom (Mankin, Mow, Buckwalter, Lannotti, & Ratcliffe, 1994).

The triple helix of α -chains undergoes modification before being secreted from the endoplasmic reticulum (ER). Selected proline and lysine amino acids are subjected to hydroxylation followed by glycosylation. Hydroxyproline is essential for constituting a helical structure, while the process of adding galactose and glucose to the hydroxylysine determines the size of the collagen fibrils (Stockwell, 1979).

Post-translational modification then takes place extracellularly, where crosslinking of enzymes initiates collagen molecules to self-assemble into D-staggered-arrays with unique patterns of bands repeated every 67 nm (Refer Figure 2.1) (J. Buckwalter et al., 1987).

There are a few types of collagen in articular cartilage. Those that form the basic architecture are type II (about 90-95%) and a member in the subgroup Fibril Associated Collagens with Interrupted Triple helices (FACITs), type IX and type XI collagen that can be found within the fibrils. Besides these, small amounts of types III, VI, XII and XIV collagen can be found in this tissue (Eyre, 2002).

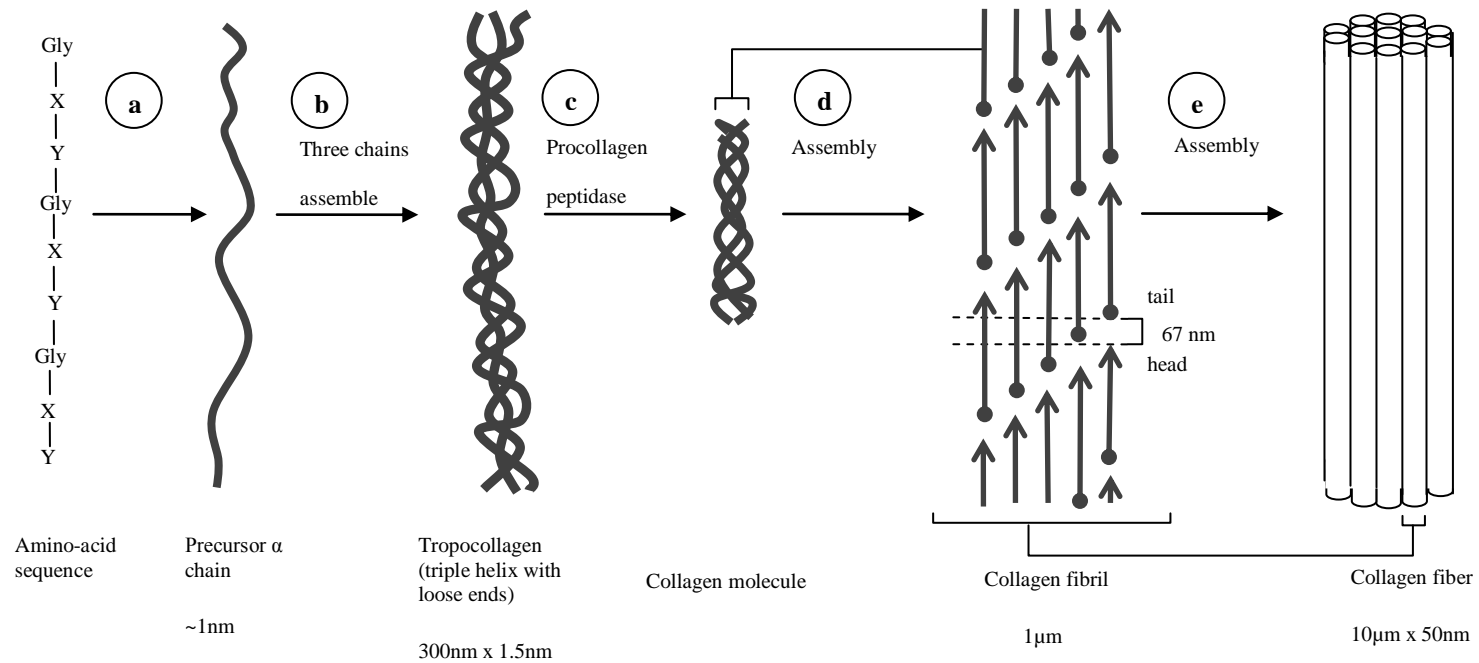

Figure 2.1 Collagen fibril and triple helix tropocollagen. (a-c) Repeating disaccharides building an amino acid sequence called precursor that coils left-handedly to form a triple helix. (d) The propeptides cleaved together to form collagen fibrils. The distance between the “head” (\uparrow) and the “tail” (\bullet) of the next collagen molecule is constantly about 67nm. This constant value is important for the collagen fibrils to produce a structured formation called “staggered-array”. The interactions between parallel groups are moderated by covalent bonds. (e) Bunch of collagen fibrils are densely-packed forming collagen fibers. Adapted from Lodish, Berk et al. (2000) and Massachusetts Institute of Technology (2006).

Generally, collagen in articular cartilage provides the dominantly tensile behaviour of the tissue. Collagen also immobilizes the proteoglycans within the ECM (Mankin et al., 1994; Mow et al., 1990; R. Schulz & Bader, 2007; Yang & Elisseeff, 2006). This characteristic is due to the formation of collagen fibres (due to the triple-helical structure of collagen molecules) and zonal arrangement (Figure 2.2); in terms of fibrillar architecture with tissue depth.

The structure and protein distribution of cartilage can be signified in four zones of cartilage (Figure 2.2). The four zones are superficial, middle, deep and calcified cartilage. The collagen fibrils in the superficial zone are thin, condensed and lie parallel to the plane of the articular surface. The highly ordered collagen fibres are essential in providing AC with shear stress resistance, as this region of cartilage embraces tangential tensile stress (Mow et al., 1990).

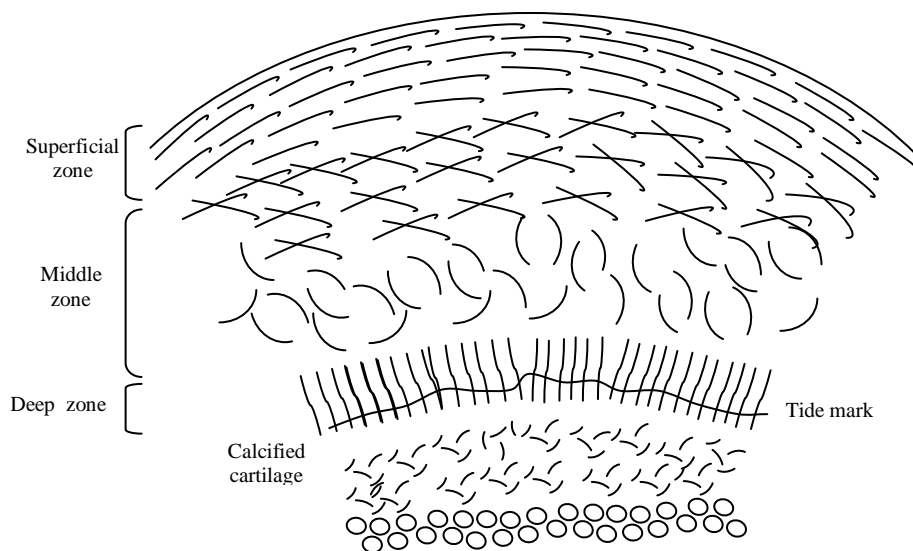

Figure 2.2 Zonal arrangement of fibrillar architecture. From outermost (contact with AC) to innermost (next to subchondral bone): superficial zone, middle zone, deep zone and calcified zone. Adapted from Mow, Fithian et al. (1990).

The scanning electron microscopy (SEM) shows that collagen fibrils in the deep zone are structured orthogonally to the surface of the articular cartilage (Eyre, 2002; R. Schulz & Bader, 2007). In this region, fibre diameters are bigger than the fibres in other regions to provide compressive strength (Stockwell, 1979). About 5-10% of the matrix volume in the calcified region is occupied with collagen fibrils aligned radially (Bader & Lee, 2000).

2.1.3. Proteoglycan

Proteoglycans (PGs) are high molecular weight glycoproteins, a combination of both protein and polysaccharides. PGs are responsible for cartilage withstanding compression (Iozzo, 2000).

PGs consist of protein cores and at least one glycosaminoglycan (GAG) chain comprised of disaccharides of amino sugar. The GAGs are covalently attached to the protein core forming a brush bottle-like structure (Figure 2.3). PGs in AC coagulate to form aggrecan. The aggregation of PGs has become possible due to the G1 domain of the core protein affixed noncovalently to the hyaluronic acid (HA) chain (Figure 2.4) marked by the hyaluronate (J. Buckwalter et al., 1987).

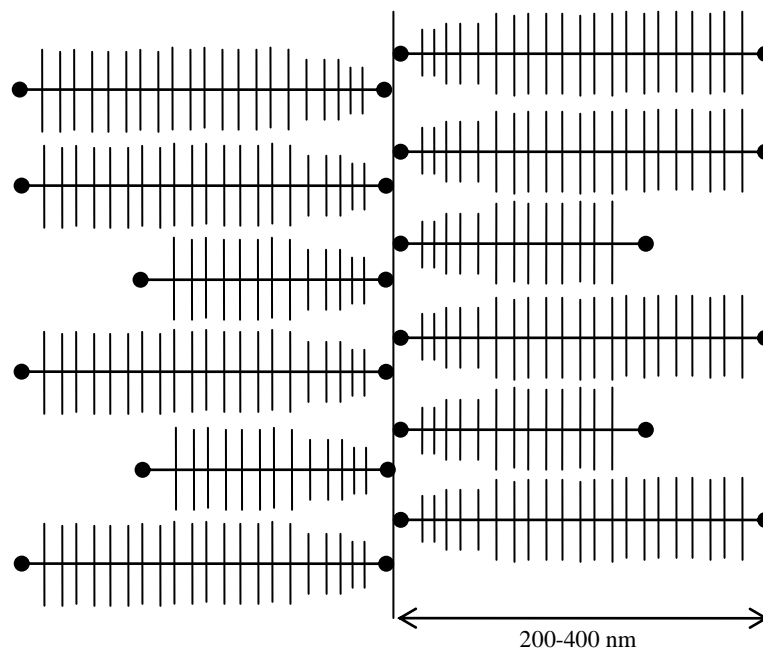

Figure 2.3 Brush-bottle-like structure of proteoglycan. Adapted from Iozzo (2000).

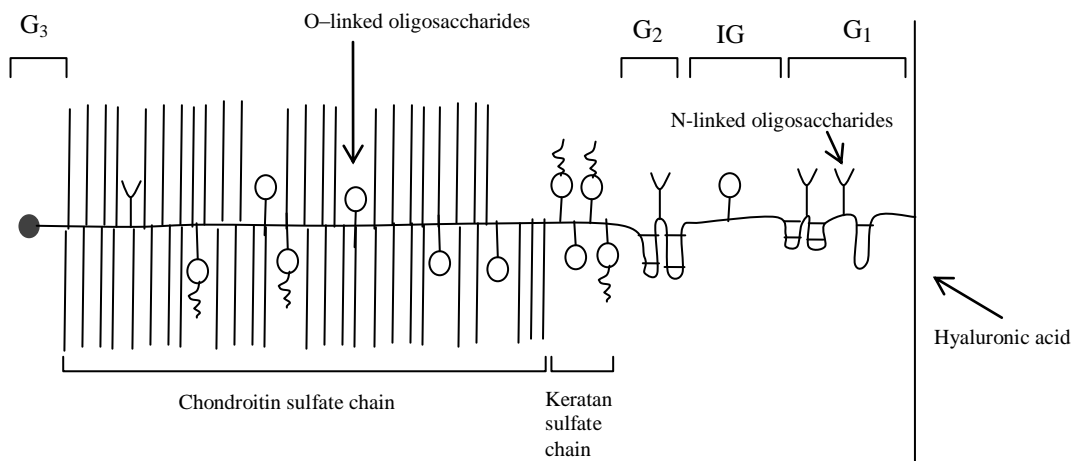

Figure 2.4 Aggrecan attached to hyaluronic acid (HA). N-terminal of G₁ domain binds to HA, G₂ is the second globular region, and G₃ is the C-terminal domain of aggrecan. IG stands for the immunoglobulin domain. Adapted from Kiani, Chen et al. (2002) and Paulsson, Morgelin et al. (1987).

G1 domain at the aggrecan constitutes cysteine-rich motifs that form disulphide bonds (Figure 2.5). The disulphide bonds are responsible for linking the aggrecan with HA (Kiani et al., 2002). PG aggregation is important for trapping water molecules within the articular cartilage. Unlike chondroitin sulphate and keratin sulphate that have sulphate ($-\text{SO}_4$) groups bound to them, hyaluronate, another type of GAG, has carboxyl (COOH) groups. The ionized structures of these two groups (COO^- and SO_3^-) attract positive counter ions to balance the charge in the ECM. The positively charged ions build up Donnan osmotic pressure effect, facilitating water containing electrolytes and nutrients migrating into the ECM (Alberts, Johnson, & Lewis, 2002; Doherty, Lanyon, & Ralston, 2002; Mankin et al., 1994; Temenoff & Mikos, 2000).

The compressive stiffness of cartilage is enhanced by the repulsive force due to negatively charged molecules pushing against each other when the cartilage is compressed (Mansour, 2003).

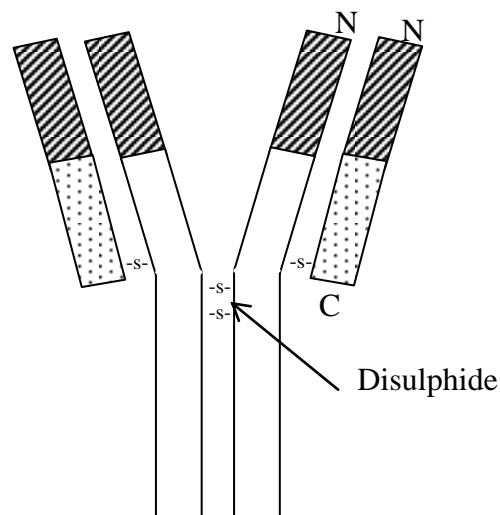

Figure 2.5 The immunoglobulin protein at the G₁ region contains two heavy and two light chains. The hyaluronic acid interacts to aggrecan through the disulphide bonds. Adapted from Brown (2002).

2.1.4. Other Extracellular Matrix Molecules

Glycoproteins help to sustain the ECM and are involved in the chondrocyte-matrix interaction. The physical properties of cartilage and its cellular function are influenced by the supramolecular assembly of the cartilage matrix, coordinated by a group of small molecules called non-collagenous proteins, such as integrin, chondronectin, fibronectin and cartilage oligomeric matrix protein (COMP).

Integrins are found transversely aligned at the cell membrane with two glycoprotein subunits on the extracellular side, serving as binding sites for cell-ECM and cell-cell adherence. Integrin receptors act as the adhesion sites between chondrocytes and fibronectins. This complex integration is mediated by COMP (Di Cesare et al., 2002). Intracellularly, environmental and mechanical stimuli signalling are sent to the cytoskeleton protein through the integrins (Mankin et al., 1994).

Cartilage-specific fibronectin isoform has high affinity for decorin. Decorin is a small leucine-rich PG that has chondroitin sulphate GAG attached (Gendelman, Burton-Wurster, MacLeod, & Lust, 2003). An interaction between the C-terminal domain of COMP and the non-collagenous domain of type-XI collagen has been observed (Holden et al., 2001).

2.1.5. Matrix Water

Water comprises about 80% of the volume of cartilage ECM, resultant to the hydrophilic properties of the proteoglycans. The fluid is driven from the synovial fluid to provide nutrients and oxygen to the AC and function as a lubricant to the joint (Wooley, Michele, & Radin, 2005). In the ECM, the water is entrapped within the bulky

aggrecans, making it very difficult to travel within the ECM. This impermeability along with high frictional forces enables AC to support high loads (Mankin et al., 1994).

The amount of water depends on the fixed charge density and an organization of collagen that brings to resistance to swelling due to the strength or stiffness of the collagen network.

2.1.6. Cartilage Physiology

Whilst other types of cartilage depend on perichondrium for nutrients and growth factors, the lack of a perichondrium surrounding AC means it has to rely on the synovial fluids entrapped within the AC capsule for nutrients. Nutrient inadequacy is worsened by AC being avascular.

The ECM in AC is classified as comprising three regions; pericellular, territorial and interterritorial; pericellular being the nearest and interterritorial region being the furthest from the chondrocyte (Figure 2.6).

The composition and protein structures in each zone differs. An abundance of PGs can be found in the pericellular region with non-fibrillar collagen (type-VI collagen) and non-collagenous proteins anchorin CII and decorin. The structure of collagen in the territorial region changes with proximity to the chondrocyte, the outer diameter of which is further from the cells, the fibrils forming a basket-like structure. This criss-cross formation is important for resisting mechanical impact. Toward the region that is adjacent to the inter-territorial, an irregular structure of fibril is observed. The same structure extends even to the outermost region, the inter-territorial matrix (Bhosale & Richardson, 2008; J. A. Buckwalter, 2005).

The pericellular and territorial regions are responsible for protecting the cell during loading, functioning as an attachment medium for chondrocytes, and facilitate the transmission of mechanical signals to chondrocytes. The mechanical strength of the cartilage is believed to be caused by the large fibril diameter in the interterritorial area (J. A. Buckwalter & Mankin, 1997a; Mankin et al., 1994). ECM stores cytokines and growth factors that are important to regulate chondrocytes. Type of nutrient, concentration and rate of nutrient diffusion are all profoundly controlled within the ECM (Bhosale & Richardson, 2008).

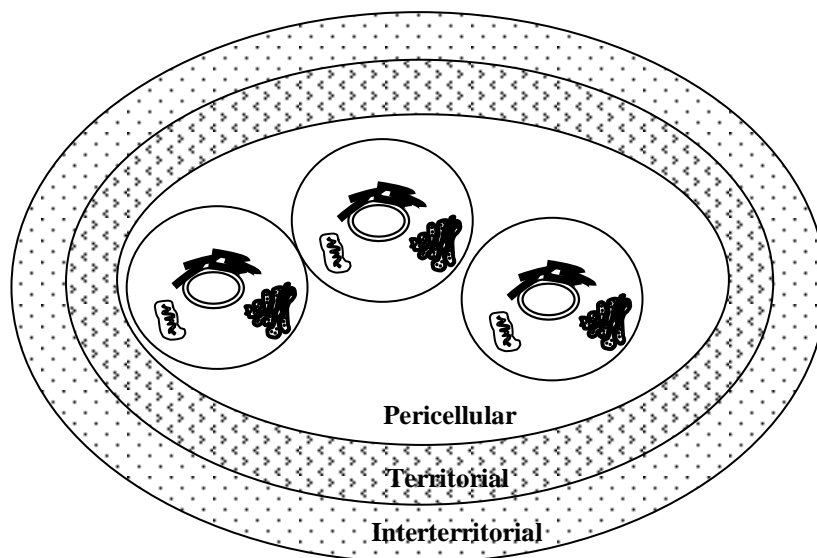

Figure 2.6 Three regions that are identified that enveloped the chondrocytes; pericellular, territorial and interterritorial. Adapted from Alberts, Bray et al. (1998).

2.1.7. Cartilage Biomechanics

AC minimizes the frictional effects between joints at rigid bones and it distributes contact pressure to the subchondral region of the trabecular region.

AC is known to have excellent mechanical properties. The unique mechanical properties revealed by the AC are attributable to the variant composition and structure including cell shape and collagen fibril orientation throughout the depth of AC (Mankin et al., 1994). The tensile and shear stiffnesses of AC are contributed by the collagen fibril structure. The tensile modulus of the articular surface of the cartilage being exposed to 0 to 5% strains varies from 3.24 to 10.2 MPa. Shear strain of 0.001 administered at 1.0 Hz and 10% compressive strain gives shear modulus of 0.68 MPa. When AC is given 0.17 MPa pressure gradients and 10% compressive strain, it shows compressive modulus of 0.79 MPa (Table 2.1). In order for the cartilage to bear high compressive loads, the collagen Type II fibres are structured in web-like structures besides dense concentration of PGs. Besides, PGs also trap fluid within the ECM that is responsible for the stress-relaxation behaviours of AC. The fluid in the cartilage sustains osmotic forces that can bear up to 0.2 MPa or 2 atm of hydrostatic pressure (J. Urban, 2000).

The superior biomechanical properties of AC are understood best when viewed as a biphasic material. The solid phase constitutes collagens and PGs. This phase is porous and permeable to the interstitial fluid that comprises the fluid phase. The fluid embodies nutrients and ions that are distributed to the chondrocytes throughout AC for the sake of maintenance of ECM. Fluid flow is induced by matrix compaction and pressure gradients. High concentrations of PGs and negatively-charged ions slow the

deformation of the tissue as they provide frictional resistance to trap the fluid from flowing out (Mankin et al., 1994; R. Schulz & Bader, 2007). With increasing compression perpendicular to the articular surface, more loads have to be endured by the collagen fibres. Tensile stress causes the collagen fibres to become aligned in the direction of the tensile force (Bader & Lee, 2000). Cartilage, being anisotropic, has more tolerance to tensile stress at the superficial zone since it contains more collagen fibres there (Mankin et al., 1994).

Table 2.1 Mechanical properties of articular cartilage. Adapted from Mow et al. (1990).

Parallel Tension (MPa)	Perpendicular Tension (MPa)	Shear (MPa)	Compression (MPa)	Permeability (m⁴/Ns)
10.2	3.24	0.68	0.79	4.7 x 10 ⁻¹⁵

When there is movement at the knee joint, the gliding of the proximal end of the femur and tibia bone will cause shear stress. Collagen fibrils will stretch in response to the shear stress without altering the volume, the pressure gradient, or causing fluid flow (R. Schulz & Bader, 2007).

2.2. Chondrocytes

Chondrocytes manufacture, secrete and regulate components of the ECM. Chondrocytes are spheroidal in shape with an average diameter of 9.0 ±0.3µm (Nguyen et al., 2010).

2.2.1. Internal Structures

Chondrocytes are a type of cell found in cartilage. Chondrocytes are isolated in small lacunae within the matrix. The cells interact with the ECM for feedback in terms of mechanical transduction and biochemical pathways. Organelles such as ER, Golgi membrane and secretory vesicles can be found encased in chondrocytes. The functions of these organelles are described in Table 2.2.

The cytoskeleton consists of actin microfilaments (MFs), microtubules (MTs) and intermediate filaments (IFs). The supramolecular structure actin generates forces needed for dynamic cellular transport processes. MFs also assist cells to change their form and

Table 2.2 List of functions for each organelle found in chondrocytes. Adapted from Minuth, Strehl et al. (2005) and Scheffler (1999).

Organelle	Function
Nucleus	The nucleus is the “brain” for cells. Chromosomes that contain genetic information can be found in the nucleus. Two identical chromatids linked together via centromere are called chromosomes. Deoxyribonucleic acids (DNA) that have genetic information fabricate each chromatid.
Mitochondria	Organelles that generate power to transport enzymes in the cell are called mitochondria. This rod-like organelle converts oxygen and nutrients into adenosine triphosphate (ATP). In the absence of oxygen, cells obtain energy from anaerobic respiration that is less efficient than aerobic respiration.
Endoplasmic reticulum (ER)	The ER is an important organelle in protein synthesis. The rough ER is coated with ribosomes that are made of strands of ribonucleic acids (RNA). In protein synthesis, DNA will provide instruction to build protein through messenger RNA (mRNA) that is transported by the transfer RNA (tRNA) to the ribosome to be polymerized.
Golgi Apparatus	Transport vesicles that contain newly synthesized proteins are dispatched from ER to the Golgi apparatus, where proteins are processed until completion.

migrate (Schuler, Karlsson, Schutt, & Lindberg, 2006). MTs consist of two highly-homologous proteins called α -tubulin and β -tubulin that are arranged to form a loose, basket-like structure. MTs serve as tracks which manoeuvre transport vesicles (Langelier, Suetterlin, Hoemann, Aebi, & Buschmann, 2000; Michels, 2002). Fibres with a diameter of about 10nm form a rope-like structure constituting the IFs. Each fibre consists of an amino-terminal globular head, a carboxyl-terminal globular tail and a central elongated rod domain. The rope-like structure is initiated by α -helical dimers of the rod domain (Alberts et al., 1998). IFs enable cells to withstand the stress of cell stretching. IFs directly send signals for cell deformation, making them essential for mechanotransduction. It was also found that IFs are abundant at the weight-bearing region of cartilage (Langelier et al., 2000).

2.2.2. Chondrocytes Metabolism

It is believed that cilia extending from the cell assist sensing mechanical changes in the ECM. Chondrocytes are initially differentiated from MSC (Tuan, Boland, & Tuli, 2003; R. Tuli et al., 2003). The cell then divides and produces two zones of matrix; peripheral and central. The function of the matrix is to expand the articular surface, while the central matrix serves as the centre of endochondral ossification of the epiphysis. Maintenance of the ECM is the responsibility of chondrocytes by continuing to synthesize proteins, despite the inability of chondrocytes to proliferate once matured. Hence, cell capacity degrades with age and the remaining chondrocytes can no longer compensate for the catabolic activity of the AC (J. A. Buckwalter & Mankin, 1997b). The final stage of the development of growth plate cartilage is conveyed by the turnover of matrix, mineralization, marrow vasculature and chondrocyte apoptosis (Farach-Carson et al., 2006).

In addition, the reduced cell capacity is also impaired by the limited nutrients that can reach the chondrocyte due to the double diffusion barrier and charges. The low permeability of the cartilage forces it to depend solely on anaerobic metabolism due to the low concentration of oxygen in the chondrocytes (J. A. Buckwalter & Mankin, 1997a).

2.2.3. Zonal Variation in Chondrocyte Morphology

Referring to Figure 2.2, the uppermost zone of cartilage, the superficial zone is bathed in the synovial fluid. Elongated chondrocytes lie parallel to the articular surface at the bottom of the superficial layer, adjacent to the middle layer. The properties are vital to accommodate the prolonged gliding motion of the articular joint as well as to absorb mechanical shock. The superficial zone of the AC is capable to merge to the surface of the proximal end of the femur, due to the low glycosaminoglycan content and compressive modulus (Yang & Elisseeff, 2006).

The middle zone appears as rounded chondrocytes aligned in the same arrangement as the collagen fibrils. Further, chondrocytes in the deep zone are spherical in shape and each cytoplasm is stocked with ER, Golgi apparatus and mitochondria (J. A. Buckwalter, 2005). The deep and calcified zones are distinctively separated by the tidemark (Mankin et al., 1994). The cells in the calcified zone have nearly no endoplasmic reticulum (J. A. Buckwalter, 2005).

2.2.4. Chondrocyte-ECM Interaction

Dynamic reciprocity between the ECM and the chondrocytes to regulate adhesion, migration, cell division, differentiation, dedifferentiation and apoptosis is modulated by the signalling cascade sent via the cytoskeleton.

Chondrocyte adhesion molecules are the means to transmit signals from the extracellular region to the cell. Some of the adhesion molecules that have been identified are integrin, CD44 and human melanoma proteoglycan (HMPG/NG2). Fibronectin adhesion to $\alpha 5\beta 1$ integrin, in association with mechanical stimulus leads to phosphorylation of signalling molecules in the MAP kinase pathway, while $\alpha 2\beta 1$ integrin provides adhesion site for the type-II and type-VI collagen (Helfrich & Horton, 2006).

2.2.5. Articular Cartilage Pathology

As the natural turnover level of cartilage and its ability to repair itself are both relatively slow, minor injuries or lesions may lead to progressive damage of cartilage. Unlike other types of tissues that can regenerate or heal intrinsically, cartilage, being avascular, has a confined supply of nutrients because the fluid that contains nutrients can only diffuse through the matrix, not being brought directly through blood vessels. Its limited regenerative potentialities are also due to the dense composition of cartilage (R. L. Mauck, Seyhan, Ateshian, & Hung, 2002).

Under normal conditions, low levels of degradative and synthetic enzyme activities are balanced in order to maintain the volume of cartilage. In osteoarthritis (OA) phenomena, matrix degrading enzymes are over-expressed compared to the constructive enzyme, resulting in loss of collagen and PGs from the ECM.

OA is a degenerative joint disease that mainly arises from the cumulative effect of joint wear and tear, especially at weight-bearing joints areas. Enzymatic degradation by aggrecanase, collagenase and stromelysin reduces the concentration of aggrecan and collagen. As a result, the water concentration and swelling pressure in cartilage

increases and disrupts type-II collagen fibres. Destruction of the framework exposes the cartilage to risk of load-bearing injury, since the PGs are not substantially contained (Doherty et al., 2002).

Besides OA, rheumatoid arthritis is a joint autoimmune disease (Cotran, Kumar, & Collins, 1999). It starts with swelling, followed by lymphocytes and macrophages entrapped within the synovial membrane. These antigens initiate the chronic inflammatory process where inflammatory granulation tissue is replaced by fibrous or bony ankylosis (Doherty et al., 2002).

2.3. Tissue Engineering of Cartilage

Current treatments for degraded AC include cartilage transplantation and the implantation of artificial polymers or metal prostheses. Transplantation is dependent on limited donor tissue, while some studies on artificial prostheses have shown insufficient mechanical strength and damage to the prosthesis, leading to chronic tissue inflammation (Langer & Vacanti, 1993).

The US Food and Drug Administration (FDA) approved autologous chondrocyte implantation (ACI) as a two-step procedure. Initially, chondrocytes are isolated from a cartilage biopsy taken from a joint that is low-weight-bearing. The cells are then expanded *in-vitro* to obtain sufficient numbers of cells. The cells, aspirated into a syringe are then transferred to the cleaned lesion and covered with a periosteal flap. Low to non-weight bearing active movement of the joint commences a few days after surgery for rehabilitation purposes (Lindahl, Brittberg, & Peterson, 2003). The mechanical strength of the resulting cartilage is debatable. Decline in mechanical strength is believed to result from the non-uniform spatial distribution of chondrocytes

and that the cells injected originated from non-weight bearing areas (Ringe & Sittinger, 2009; Temenoff & Mikos, 2000). However, a recent study has shown that the distribution of cultured cells can be well distributed by attaching an angiocatheter onto the syringe that contains cell suspension (Brittberg, 2008). Furthermore, the fibrocartilage-like structure that was alleged to have low mechanical strength was observed to eventually transform into hyaline cartilage due to loading (Lindahl et al., 2003).

As explained in Chapter 1, the three main components of TE are cells, matrix and signalling molecules. By far, chondrocytes are the best cellular candidates for cartilage TE. Initial problems faced in getting sufficient chondrocytes are solved by expanding cells *in-vitro*. However, cartilage cells cultured in monolayer for extended periods have shown to change to the dedifferentiated fibroblastic phenotype and their function change as they synthesize cartilage more fibrous-like in structure (H. W. Kim & Han, 2000). Besides cell dedifferentiation, there are also concerns related to donor site morbidity and the limited life span of cells once extracted. These drawbacks have motivated research into the possibility of using mesenchymal stem cells (MSCs) or mesenchymal progenitor cells (MPCs) for such applications (Tuan et al., 2003; Tuli, Li, & Tuan, 2003).

The biggest challenge in cartilage TE is to engineer weight-bearing tissue with multiphasic cellular architecture. An effort to tackle this problem is to modify matrices used to hold the structure of the cell seeded construct called the scaffolds. Increasingly favoured porous 3D scaffolds that provide superior mechanical properties have been used to assist cellular attachment. Besides mechanical properties, bonding to the host

tissue, biocompatibility and internal cohesiveness need to be considered. In an attempt to avoid the need for invasive surgery injectable, biocompatible and biodegradable scaffolds have been used to encapsulate isolated chondrocyte at the defect. Yet, being biodegradable, the material used is inferior in terms of its mechanical properties (Sims et al., 1996). Most current endeavours to come up with heterogeneous scaffolds to mimic multiphasic cartilaginous tissue have given positive results and currently these scaffolds are at the stage of lab testing (Richard Tuli et al., 2003).

Besides cells and scaffolds, research has been carried out to integrate the applications of bioreactors to cartilage TE. The use of bioreactors has enabled uniform distribution of cells, efficient transport of biochemical initiators (i.e. growth factors) and precise control of mass transfer rate, nutrient levels and pH. Besides, literature reports the application of bioreactors to deliver physical stimuli to mimic in-vivo chondrogenesis (Cooper et al., 2007; R. M. Schulz et al., 2008; R. Smith, Trindade, et al., 2000).

2.4. Mechanotransduction

The study of mechanical effects on cartilage metabolism has evolved since osteoarthritis was associated with mechanical stress (Wilkins, Browning, & Urban, 2000).

Mechanical forces and deformations are sensed by cells and turned into biochemical signals. The transduction of mechanical stress into biochemical signals by cells is known as mechanotransduction. Signals are essential to adjust cellular and extracellular structure. This evolution is essential in regulating chondrocyte function; both in metabolic and catabolic *modus operandi*. The regulation can either be by proliferation, differentiation, migration or apoptosis of cells. The organization and distribution of

structural elements and organelles within cells adapt to the static and dynamic physical stimuli; depending on the amplitude, frequency and duration of load given (Jennifer, John, & Alan, 2003; Mobasheri et al., 2005).

2.4.1. Mechanical Signal Transduction at Multiple Levels

Tissue Level

Research has shown that a series of consequences such as extraction of fluid from the cartilage ECM, the increase in cation concentration and extracellular osmolarity and decrease in extracellular pH in ECM result from exposure of static loading of the cartilage (Hart & Miller, 2004; Sharma, Saxena, & Mishra, 2007). On the other hand, when cartilage is subjected to cyclic loading, the occurrence of hydrostatic pressure and interstitial fluid flow have been observed in ECM (Chao, West, & Hung, 2006; Wilkins et al., 2000; Wolf, Ackermann, & Steinmeyer, 2007).

Dynamic loading derives interstitial fluid flow. Fluid effusion exerts shear stress to chondrocytes and their surrounding, since the permeability of the ECM is limited due to the frictional drag force. The drag force can be contravened by the large speed of interstitial fluid flow due to the compressive loads on cartilage. Therefore, interstitial fluid flow not only accelerates transportation of low-infused macromolecules, it also mobilizes the cation. When fluid exudates during compression, leaving negatively charge PGs, cations will be drawn into the ECM (Hart & Miller, 2004). Furthermore, this convective motion facilitates the transport of larger molecules such as growth factors, cytokines and enzymes. The membrane transport process works better with the aid of convective transport since it must counteract the small void between glycosaminoglycan chains. The void size is around 30-40Å (J. Urban, 1994).

Being biphasic, cartilage needs equilibrium in terms of its solid and fluid contents in order to withstand mechanical stress. Under prolonged exposure to static loading, fluid loss increases the osmolarity of the ECM of cartilage as the ratio of PGs to fluid increases. This change activates osmotically-gated ion channels that send signals to chondrocytes to stop producing PGs (Oswald, Chao, Bulinski, Ateshian, & Hung, 2008; J. Urban, 1994; Villanueva, Gladem, Kessler, & Bryant, 2009).

Anabolic and catabolic processes in cartilage happen anaerobically due to low oxygen content at the ECM. This produces lactic acid. In healthy joints, high concentrations of cations are attracted to the matrix to balance the negatively charge PGs. The cations facilitate reduction the extracellular pH to 6.9 (Loret & Simões, 2007). Static loading also reduces the pH of the cartilage, as interstitial fluid flows out of the tissue. As a result, protons are attracted to balance the fixed negative charges of PGs. These events of increment in lactic acid and protons do not contribute to normal growth of cartilage (Wilkins et al., 2000).

In the phenomena of applying cyclic loading on chondrocytes, the interstitial fluid flows in and out of the ECM. This movement causes streaming potentials that activate voltage-gated ion channels to up-regulate GAG synthesis, which has been proven through research that applies electrical current to chondrocytes (Akanji, Lee, & Bader, 2008).

Cellular Level

Chondrocytes reciprocate to deformational changes of cartilage. Isolated chondrocytes in high-density monolayer culture were exposed to intermittent hydrostatic pressure at a modulus of 10 MPa for 4 hours per day for 4 days. The hydrostatic pressure was given at a frequency of a normal walking motion, 1 Hz. It was observed that there was an increase in the PGs and type II collagen mRNA production (R. Smith, Lin, et al., 2000). Another study by Carver and Heath (1999) showed intermittent hydrostatic pressure applied to cells seeded in PGA scaffold exhibited a two-fold increase in the concentration of sulphated GAG than unloaded cells. MacDonald (2002) suggests that hydrostatic pressure affects the kinetics of ion channels as it was shown that there was an uptake of intracellular calcium through the reaction of the Ca^{2+} dependent Na^+ and K^+ channels.

It has been demonstrated that higher concentrations of PGs, larger cells and more intracellular organelles can be found at the load-bearing areas of cartilage (J. Urban, 1994).

Guilak et al. (1995) studied chondrocytes' shapes and volume under compression. They found that chondrocytes react differently to loading depending on their depth through the cartilage. In unstrained conditions, chondrocytes are spherical. However, when exposed to static and cyclic deformation, chondrocytes seeded in agarose/alginate gels change to oblate ellipsoid morphology (F. Guilak et al., 1995; Knight, Ghori, Lee, & Bader, 1998).

Chondrocyte volume decreases as cartilage is deformed. This might be due to fluid that is expelled from the tissue and cytoplasm. It was also found that when cartilage is loaded vertically, the vertical radii of the cartilage decreases, but its horizontal radii are unchanged (M. D. Buschmann, Hunziker, Kim, & Grodzinsky, 1996; Szafranski et al., 2004).

Intracellular Level

A study on the effects of chondrocyte compression on intracellular organelles has shown that the volume of the nucleus and other organelles change proportionally to the cell volume, except for the Golgi apparatus. Even though the shape of the nucleus is mediated by the cytoskeleton, it was concluded that intracellular osmotic gradients influence the nucleus volume. Golgi is rather incompressible. It is known that transcription process of aggrecan GAG happens in the Golgi. High density of GAG facilitates Golgi's to conserve fluid and withstand compression (Szafranski et al., 2004).

Mechanochemical transduction arises at the focal adhesion that serves as the integrin-binding site. The impulse is sent in both directions between the cytoskeleton and the ECM. This eventually activates signalling pathways and transcript the gene expression, leading to protein synthesis, cell proliferation and differentiation (Korossis, Bolland, Kearny, Fisher, & Ingham, 2005; Lucchinetti et al., 2004)

External mechanical loads such as direct compression, tensile and shear force caused cells to activate K^+ channels, increase concentrations of free Ca^{2+} intracellularly, phosphorylate protein kinases and activate transcription factors (J. K. Mouw, Case,

Guldberg, Plaas, & Levenston, 2005). Figure 2.7 shows mechanical inputs triggering signalling pathways to regulate cell growth, cell functioning and cell remodelling.

The application of shear stress on the chondrocytes was also found to modulate the metabolism of matrix through a pathway. This particular pathway involves synthesis of nitric oxide, and activations of G protein and phospholipase C (R. Smith, Lin, et al., 2000).

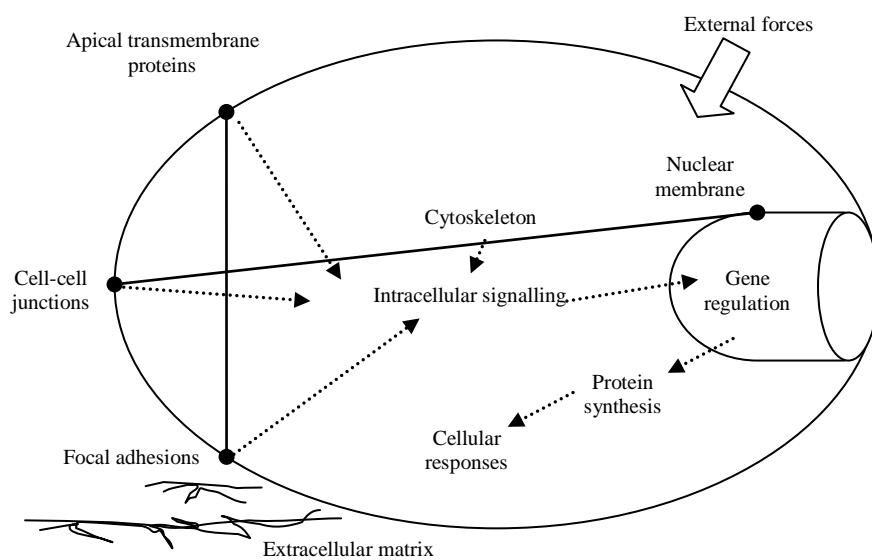

Figure 2.7 Schematic diagram of cytoskeleton during mechanotransduction. Upon experiencing shear stress, stretch and pressure; certain mechanosensors at the cytoskeleton will transmit signals that concurrently inevitable to initiate cells' regulations.

2.4.2. In-Vitro Mechanical Loading Studies

In vivo, AC is subjected to complex loading consisting of a combination of both compressive and shearing forces under normal physiological condition (Mankin et al., 1994). This complex mechanical loading was studied by multiple groups of researcher using rotating ball, however the studies applying multi-directional load were hardly quantified due to independent measures such as experimental setup (Grad et al., 2005; Grad, Lee, Wimmer, & Alini, 2006; Heiner & Martin, 2004; Stoddart, Ettinger, & Häuselmann, 2006; Wimmer et al., 2004).

Other studies that look into the effect of load to chondrocytes or cartilage explants are summarised in Table 2.3. To summarise these literature reviews, dynamic compression seems favourable for chondrocytes as dynamic compression caused increased protein deposition. A range of values from 0.1 to 1 Hz is most common when it comes to cyclic loading frequency, similar to normal human walking speed. On the other hand, physiological physical load withstood by joint cartilage is a complex load combination of compression and shear strains. The magnitudes of compression extend from 10% to 15%, while shear strains range from 1% to 5%. These figures are closely related to the weight an adult human has to withstand during walking and normal physical activities.

Table 2.3 Summary of studies that have been done to assess response of cartilage to mechanical load *in-vitro*.

References	Mechanical Regimes
M. Buschmann, Gluzband et al. (1995)	Static mechanical compression was delivered until final compressed thickness of the construct was between 0.4 mm and 1 mm. Static compression was removed after 16 hours. Dynamic compression of 0.73 mm was delivered to each disk at frequencies of 0.001, 0.01, 0.1 and 1 Hz. Compression lasted for 10 hours. It was found that dynamic compression between 0.01 to 1 Hz caused increased protein deposition with time.
Chowdury, Bader et al. (2003)	The amplitude of the mechanical compression was 15%, given at a rate of 1 Hz. A longer duration of compression (12 hours) was found to increase the PGs production, whereas a shorter intermittent compression (1.5 hours) was essential to induce cell proliferation.
Davisson, Kunig et al. (2002)	After 24 hours, GAG level of constructs subjected to 10% amplitude dynamic loading showed 80-100% increase compared to the constructs that was loaded statically. The effect was more vivid when the constructs were stimulated at 0.1Hz.
Hunter, Mouw et al. (2004)	Dynamic compression of 10% amplitude with a frequency of 0.1Hz has shown significant effect on chondrocytes that have been seeded in fibrin gels. Inhibition of GAG and hydroxyproline and simulation of nitrite were observed in samples loaded dynamically. It was also found that DNA content among samples under different conditions was not showing any significant difference.
D. Lee, Noguchi et al. (2000)	Different frequencies (0.3, 1 and 3 Hz) of 15% compression were stimulated on chondrocyte/agarose constructs for 48 hours. Compression at 0.3 Hz reduced GAG synthesis, at 1 Hz increased GAG synthesis by 40%, while at 3 Hz no significant change occurred in GAG synthesis.
Robert Mauck, Soltz et al. (2000)	After four weeks, it was found that isolated chondrocytes seeded in agarose constructs increased GAG and hydroxyproline content after compression with strain amplitude of 10% at a frequency of 1 Hz, three times a day (1 hour on and 1 hour off).

RL Mauck, Wang et al. (2003)	Intermittent deformational loading of 10% was stimulated on chondrocyte-seeded agarose for two months. The whole stimulation took place for 6 hours per day, 5 days per week. While Young's and dynamic modulus of loaded constructs were found to be different compared to the free-swelling ones, PG and collagen content were reported to be insignificantly different.
B. Pinguan-Murphy, El-Azzeh et al. (2006)	Frequency and strain rate of cyclic compression were also found to modulate calcium signalling by activating purinergic pathway causing calcium release. These were analyzed by looking at the intracellular Ca ²⁺ signalling upon dynamic loading. The loads given at 10 cycles of amplitude between 0% to 10% strains.
Sah, Kim et al. (1989)	Dynamic shear deformation (1-5% strain, 0.01 to 1 Hz) demonstrated more of up-regulation of collagen biosynthesis of cartilage explants than PG biosynthesis. At lower frequencies, compressive strain of less than 5% delivered less effect on ³ H-Proline and ³⁵ S-sulphate incorporation.
Shelton, Bader et al. (2003)	The chondrocytes seeded constructs were either exposed to tensile strain or compressive strain. Tensile cell straining systems gave 5% strain at 1 Hz for 24 hours using a sawtooth waveform, compressive strain was given at 15% at frequencies of 0.3, 1 or 3 Hz for 48 hours. The 1 Hz dynamic mechanical regimes resulted in highest GAG production. Biaxial loading showed inhibitory responses towards cell proliferation.
Villanueva et al. (2009)	Isolated bovine articular chondrocytes were embedded in PEG hydrogels incorporated with chondroitin sulphate (ChS) and exposed to dynamic mechanical stimulation (0.3 Hz, 15% amplitude strains for 6 hours). 0.3 Hz load had no effect on chondrocyte response and no chondroitin sulphate was detected in the first 12 hours. After 48 hours, the cells seeded in 20% ChS stimulated production of PGs and collagens, while inhibited production of nitrite and cell proliferation.
Waldman, Spiteri et al. (2003)	Chondrocytes cultures were mechanically stimulated for 400 cycles every second day. The amplitude of the cycle was 2% shear strain at a frequency of 1 Hz. The culture was analyzed at 1-week and 4-week points. At both points, cells contained in the scaffold not only produced more collagen and PGs, but also have better compressive mechanical properties, compared to those unloaded.

Waldman, Couto et al. (2007) Dynamic multi-axial mechanical loading was conducted for 400 cycles per day at a frequency of 0.5 Hz, for four weeks. Four combinations of compression and shear strain amplitudes were tested

- i) 2% compression – 2% shear
- ii) 5% compression – 2% shear
- iii) 2% compression – 5% shear
- iv) 5% compression – 5% shear

It was found that synthesis of ECM depends on the relative magnitudes of the applied compressive and shearing strains. Equilibrium amplitude of compression and shear strain increased the ability of cells to synthesize high concentrations of collagen and PGs.

Other studies evaluated the effect of shear stress on chondrocytes via hydrodynamic shear (Ikenoue et al., 2003; G. Jin et al., 2000; Y. Kim et al., 1995). Direct shear stress on cartilage explants (Frank, Jin, Loening, Levenston, & Grodzinsky, 2000; M. Jin, Frank, Quinn, Hunziker, & Grodzinsky, 2001) and shear stress produced by laminar fluid flow in rotatic cone viscometer (R. Smith, Lin, et al., 2000), the latter that increased the concentration of sulphated glycosaminoglycan in monolayer cultured chondrocytes. However, there is not yet any study which assesses the influence of direct shear stress on chondrocytes in 3D scaffolds.

Chapter 3. Methodology

In this section the methods used within the studies presented are set out and explained. The first section relates to the protocols used to obtain chondrocyte cells for research purposes; the second to the specific culture system used and the way in which it is prepared; the third, the methods used in biomechanical stimulation through the use of a bioreactor.

Following these is presented details of the biochemical assays used, with their limitations; and, the statistical and study design methods employed to ensure reliable analysis and fair study design.

3.1. Methods in Cell Isolation

There are a few techniques to isolate cells from tissues for ex vivo culture (Refer to Table 3.1). Enzymes such as collagenase, trypsin or protease can be used to release mononuclear cells from soft tissues. This technique is called enzymatic digestion and cells are isolated as the ECM holding the cells is degraded by the enzymatic action.

Most research has applied two-stage digestion (DiMicco, Kisiday, Gong, & Grodzinsky, 2007; Hayman, Blumberg, C, & Athanasiou, 2006; Hidvegi et al., 2006), even though some groups do not run the pre-digestion step. Bueno et al. (2007), for example, immediately exposed the dissected cartilage to collagenase type-II for 16 hours, skipping the pre-digestion stage.

According to Hayman et al. (2006) digesting the cartilage tissue in protease (0.010 g ml⁻¹) for 1.5 hours followed by collagenase (0.004 g.ml⁻¹) for 3 hours yielded the highest

Table 3.1 Summary of comparisons made between the different enzymatic digestion protocols, showing enzymes used, their concentrations and digestion times.

Pre-digestion			Overnight digestion			Reference
Enzyme	Concentration (U.ml ⁻¹)	Time (min)	Enzyme (Collagenase)	Concentration (U.ml ⁻¹)	Time (min)	
Protease (Sigma)	10	60	Type-Ia	800	960	(Hidvegi et al., 2006; D. Lee et al., 2000)
			Type-II	800	960	
			Type-XI	800	960	
	20	60	Type-XI	200	960	(DiMicco et al., 2007)
	Not specified	90	Type-II	Not specified	180	(Hayman et al., 2006)
700	60	Type-XI	100	960	(Chowdury et al., 2003)	
Pronase + Hyaluronidase	Not specified	60	Type-II	Not specified	360	(Hansen et al., 2001)
Collagenase Type-II					960	(Bueno et al., 2007)

total cell number. In another study, sliced cartilage was incubated at 37°C on rollers for one hour in 700 U.ml⁻¹ protease followed by 16 hours at 37°C in Dulbecco's Modified Eagle Medium (DMEM) and 20% Foetal Bovine Serum (FBS) supplemented with 100 U.ml⁻¹ collagenase type-XI. At the end of the experiment, the cells were resuspended in medium giving a cell concentration of 8x10⁵ cells.ml⁻¹ (Chowdury et al., 2003). Degradation of type-XI collagen destructs type-II collagen fibril meshwork, eventually disrupting the matrix components (J. A. Buckwalter & Mankin, 1997b). Gemmiti and Guldberg (2006) digested minced cartilage in 0.2% type-II collagenase in DMEM

solution in the 37°C incubator for 48 hours, yielding 10×10^5 cells.ml⁻¹, while Fröhlich et al. (2007) found that the cell yield was reduced if the cartilage was exposed to collagenase for more than 21 hours.

It was also reported that the addition of hyaluronidase along with protease in the pre-digestion stage. digests hyaluronan, a non-sulphated GAG that aids proliferation and migration of chondrocytes (Hansen et al., 2001).

3.1.1. Protocol

A standard protocol was used throughout the studies, other than in the case of the first study in which the reagents and parameters used for chondrocyte isolation were optimised. The manner in which the parameters used were established is presented within Chapter 4.

3.1.2. Reagent preparation

Standard chondrocyte culture medium was used at all stages. The culture medium contained Dulbecco's Modified Eagles Medium (DMEM) supplemented with 20% Foetal Bovine Serum (FBS). DMEM + 20% FBS was prepared by adding 100 ml of FBS and 20 ml of other components in 500 ml of DMEM. Table 3.2 shows the detailed composition of DMEM + 20% FBS.

All components were mixed and filtered through a 0.22 µm pore cellulose acetate filter, prior to being aliquoted and stored at -20°C.

Table 3.2 Components of Chondrocyte Medium

Components	Stock Concentration	Quantity	Final Concentration	Supplier
Dulbecco's Modified Eagle Medium (DMEM)	NA	500ml	NA	Sigma-Aldrich, Malaysia
Penicillin/ Streptomycin	10,000units.ml ⁻¹ / 10mg.ml ⁻¹	5ml	100 units.ml ⁻¹ / 10 mg.ml ⁻¹	Sigma-Aldrich, Malaysia
L-Glutamine	200mM	5ml	2mM	Sigma-Aldrich, Malaysia
Hepes buffer	1M	10ml	2mM	Sigma-Aldrich, Malaysia
L-Ascorbic Acid	NA	0.075g	0.85µM	Sigma-Aldrich, Malaysia
Foetal Bovine Serum (FBS)	NA	100ml	16.1% (v/v)	Sigma-Aldrich, Malaysia

Buffers

Earl's Balanced Salt Solution (EBSS) (Sigma-Aldrich, Malaysia, E2888) with sodium bicarbonate was used for chondrocyte culture.

Types of Digestion Enzymes

Protease

Protease from *Streptomyces griseus* at 20 U.ml⁻¹ in DMEM + 20% FBS was used as the pre-digestion enzyme. Upon mixing, the solution was passed through a 0.22 µm pore cellulose-acetate filter, aliquoted into 20 ml vials and stored at -20°C.

Collagenase

Types of collagenases which were used for the purposes of optimisation of matrix digestion are presented in Table 3.3.

All the collagenases were supplied as a lyophilised powder and each type was dissolved in DMEM + 20% FBS at an activity of 200 U.ml⁻¹. This solution was then filtered through a 0.22 µm pore cellulose-acetate filter, aliquoted into 20 ml vials and stored at -20°C For the study of the effect of collagenase concentration; collagenase Type II was prepared at 100 U.ml⁻¹. All the collagenases were purchased from Sigma, Malaysia.

3.1.3. Bovine Chondrocytes Isolation

Bovine articular cartilage was obtained from cow joints taken from the abattoir at the Department of Veterinary Services, Shah Alam, Selangor. The cells were isolated on the same day the 18-24 months old *Bos indicus* calf was slaughtered. AC was dissected from this fresh metacarpalphalangeal joint having been immersed in 70% Industrial Methylated Spirits (IMS) for about 15 minutes. The full thickness of cartilage from the entire proximal surface of the joint was removed in the class II laminar hood (see Figure 3.1). The dissected cartilage was immersed in a 60 mm petri-dish containing DMEM+20% FBS to replenish the cartilage with nutrients.

Table 3.3 Types of Collagenase and Concentration used during the experimental work.

Collagenase Type	Specific Activity (U.ml⁻¹)	
Type Ia	200	
Type XI	200	
Type II	100	200



Figure 3.1 Exposure of articular surfaces from a metacarpal-phalangeal joint.

Subsequently, the medium was aspirated and the explant cartilage was transferred into Falcon tubes. The explant was immersed in protease (Sigma-Aldrich, Malaysia) that had been diluted to 20 U.ml⁻¹ in DMEM + 20% FBS. The first stage of digestion proceeded for one hour in the incubator at 37 °C and 5% CO₂, followed by the second stage where the cartilage fragments were immersed in collagenase with DMEM + 20% FBS. To ensure that all cartilage fragments were fully exposed to the enzymes, the Falcon tubes containing cartilage fragments were left for 14, 15 or 16 hours in a hybridization oven (LabNet, Malaysia).

After overnight digestion, the supernatant containing released chondrocytes was passed through a 70 µm cell sieve (BD Bioscience, Malaysia) into sterile Falcon tubes. The supernatant was washed twice with DMEM + 20% FBS to stop the reaction of any remaining proteolytic enzyme. It was centrifuged at 2000 RPM for 5 minutes. Finally, the cell pellet was resuspended in 10 ml of DMEM + 20% FBS.

Prior to the cell count, the cells were mixed with syringes and 21 gauge needles. The use of syringes and needles is believed to disaggregate the cells and distribute them throughout the suspension.

3.1.4. Cell Count and Cell Viability

Cell count and cell viability were ascertained using haemocytometer and trypan blue dye exclusion. 20 µl samples of the cell suspension were micropipetted and mixed with trypan blue solution at the ratio of 1:1 (v/v). Trypan blue (Sigma-Aldrich, Poole, UK) stain is commonly used to trace non-viable cells as nucleus from dead cells absorb the dye and appear blue in colour. Equation 3.1 explains the method to calculate number of cells in a one ml volume from the 20µl sample. Cell counting was performed three times and a mean value was calculated to reduce errors.

$$\begin{aligned} & \textit{Number of cells per ml} \\ & = \textit{Number of cells counted per mm}^3 \times \textit{dilution factor} \times 10000 \end{aligned}$$

Equation 3.1 Neubauer Ruling

3.2. Methods in Culture Preparation

After the cell counting using Trypan blue exclusion, chondrocytes are finally resuspended in medium to give a total cell concentration of about $8 \times 10^6 \text{ cells.ml}^{-1}$. EBSS that contains sodium bicarbonate was added into low gelling agarose (Type VII, Sigma-

Aldrich, Malaysia) at 8% (w/v) following the method of Knight et al.(2006) and autoclaved. The autoclaving procedure was to make sure the proper mixing of agarose with EBSS and sterilisation of the agarose powder. Consequently, the mixture was left on the roller mixer until the temperature of the gel reduced to about 37°C. Cell suspension was added to an equal volume of 8% agarose. The final concentration of cell-agarose mixture would be 4×10^6 cells.ml⁻¹. For mixing purposes, the glass bijou tube containing the cell-agarose mixture was placed on the rollers again and allowed to mix thoroughly.

3.2.1. Preparation of Chondrocyte-Agarose Constructs with Porous Glass Endplates

The Perspex mould consists of three parts; base, mould divider and lid (Figure 3.2). The middle part was attached to the base with two strips of 5 mm thickness porous glass (R&H Filter Co. Inc, Georgetown, US) inserted into the slot of the mould divider (Figure 3.2b). The porous glass was autoclaved prior to use while the Perspex parts were immersed in 70% IMS overnight. Then, the cell-agarose suspension was pipetted into the sterile mould, in between the two strips of porous glass. The lid was then carefully fixed on top of the mould divider to restrain from bubble formation in the agarose gels (Figure 3.2c). The whole mould was kept in the chiller at 7°C for a few minutes.

Once the agarose was fixed, the lid and mould divider were carefully lifted up. One mould will produce six samples of (5x5x5) mm of chondrocytes-agarose constructs in cubic shapes. Mini polyethylene (PE) screws were used to fasten the end parts of the porous glass strips to the shear and compression brackets (Figure 3.3). A custom handle

was designed to transfer the attached cell-agarose constructs, porous glass strips together with the brackets to the test rig (Figure 3.4).

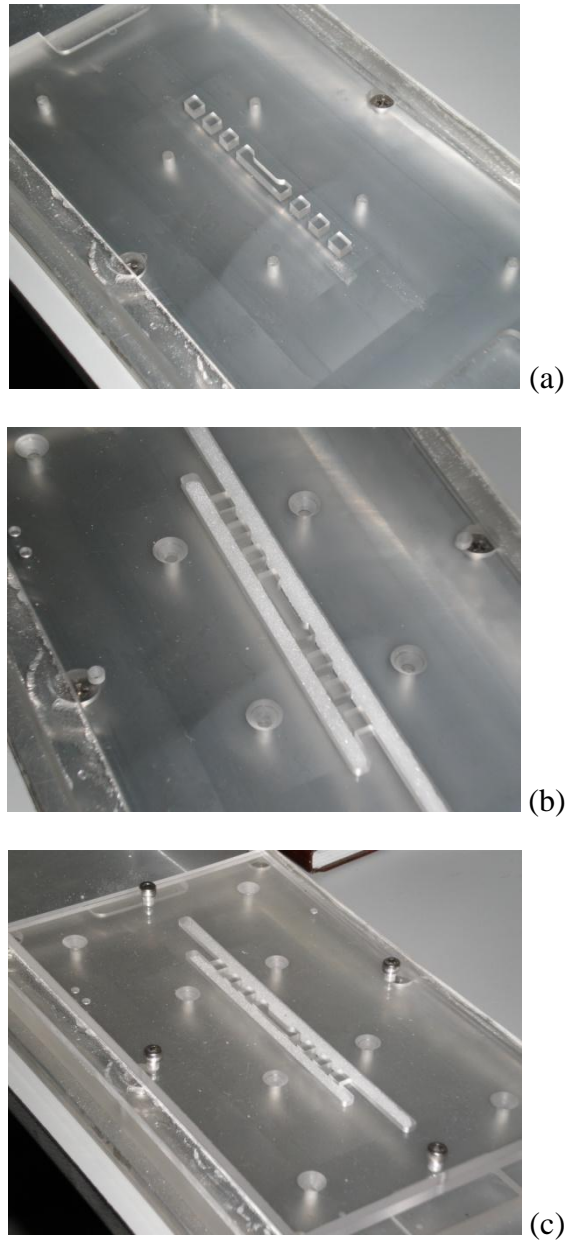

Figure 3.2 Figures showing assembly of the Perspex mould. The perspex mould is comprised of base (a), mould divider and lid. (b) Sintered glass strips were inserted into the slot of mould divider. (c) Once the chondrocyte-agarose suspension was pipette in the voids, the lid was screwed to avoid bubble formation. The mould is used to attach the agarose-chondrocyte constructs to the sintered glass strips.

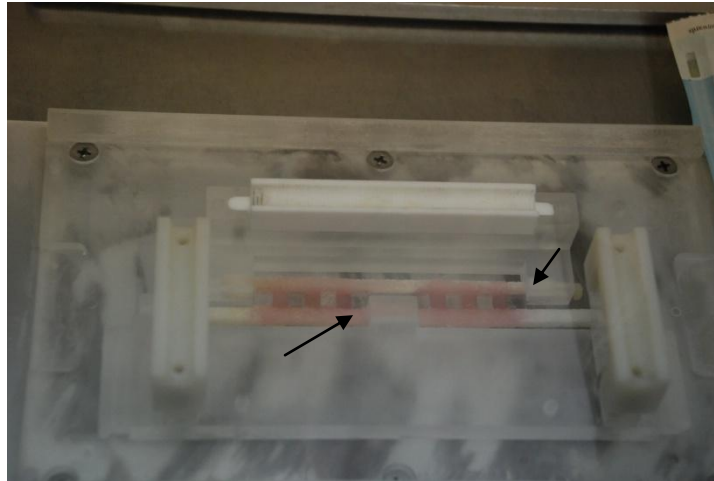

Figure 3.3 Photo of the plated constructs structure inside the culture tray. Arrow showed the sintered glass strips attached to the shear and compressive brackets with six samples of chondrocyte-agarose constructs sandwich between the sintered glass.

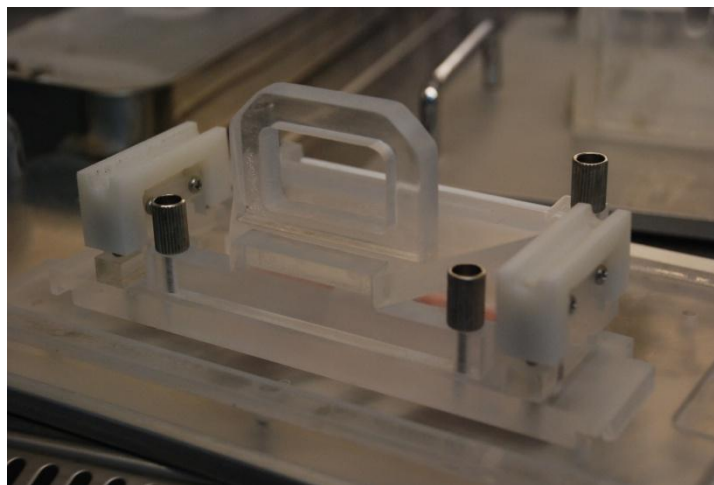

Figure 3.4 Upon lifting up the lid and mould divider, the sintered glass strips are attached to the shear and compressive brackets. Custom-made handle is then used to transfer the brackets to the test rig.

3.2.2. Preparation of Chondrocyte-Agarose Constructs for Unstrained Samples

Control samples were cultured in a 6-well culture plate. Each well contained a (5x5x5) mm agarose construct. Six constructs were prepared in a rectangular shaped Perspex moulds that has three components named as lid, base and mould divider (Figure 3.5 a). Once the base and the mould divider were securely attached using tape, two (4x5x5) mm sintered porous glass endplates (R&H Filter Co. Inc, Georgetown, US)

were laid into each individual mould using sterile forceps. The porous glass endplates were autoclaved prior to use and the Perspex parts were immersed in 70% IMS overnight. The void between the two endplates was filled with molten cell-agarose suspension, using a Pasteur pipette. The lid was placed on top to avoid bubble formation (Figure 3.5b).

Hardened constructs fixed to the porous glass endplates were transferred to the 6-well culture plate which was pre-filled with DMEM+20%FBS.

a)

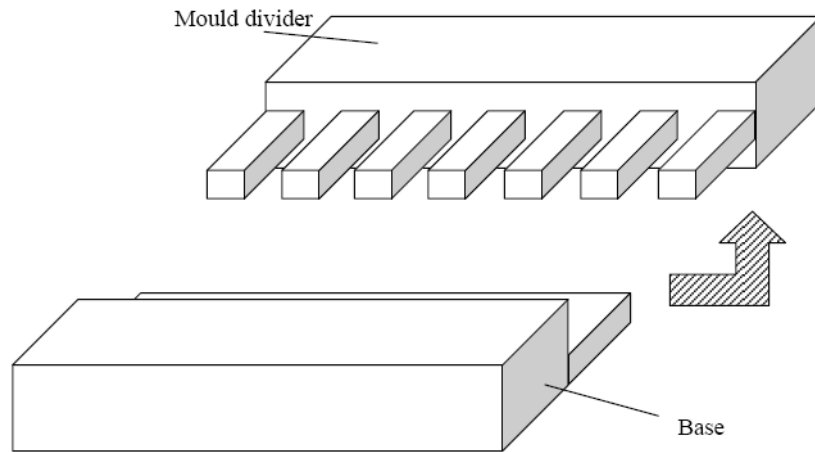

b)

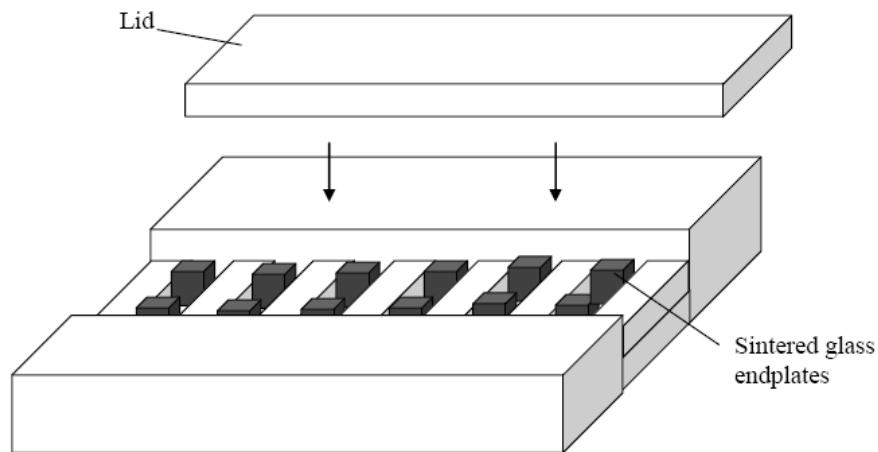

Figure 3.5 Schematic drawing of Perspex mould to produce agarose-chondrocyte-sintered glass constructs. (a) Mould divider attached to the base and (b) chondrocyte-agarose suspension pipette in the voids and was covered with lid. The specimens were then put into a 6-well plate filled with culture medium. These specimens were then tested as the control or free-swelling samples.

3.3. Methods in Biomechanical Stimulation

A test rig was designed to facilitate the compression and shear compression on the cell-agarose constructs. As mentioned above, the brackets hold the porous glass strip that contains cell-agarose constructs. The brackets move vertically or horizontally to give a direct or shear loading to the constructs. Stepper motors and PLC system were used to modulate mechanical regimes as desired (Figure 3.6).

The slots located at the bottom of the brackets were placed on the rail at the test rig. The rail is a long strip of Perspex augmented on the base of the test rig and its function is to guide the bracket during loading.

The shear and compression movements of the brackets were driven by stainless steel (SS) column the surfaces of which were threaded (Figure 3.7). Prior to the transportation of the test rig into the incubator, the rig was covered with a lid to ensure sterility (Figure 3.8).

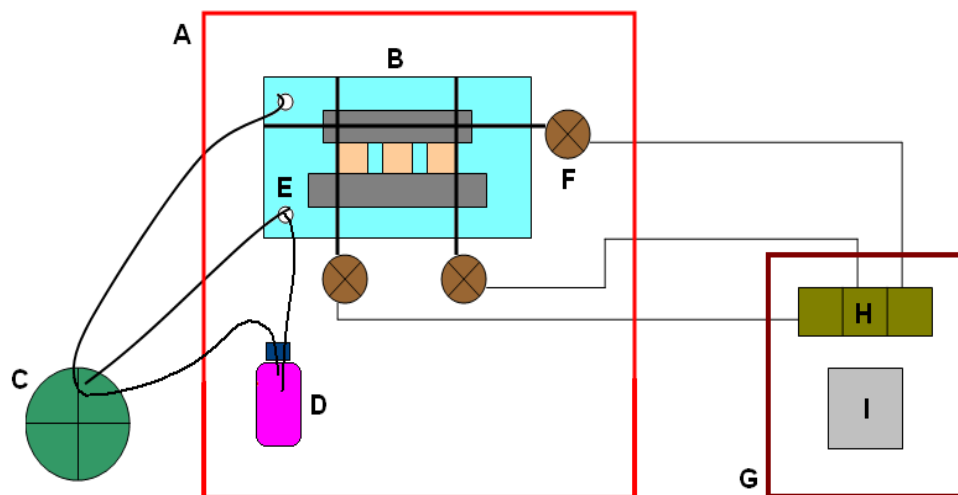

Figure 3.6 The schematic representation of the configuration of the incubator-housed and PLC-controlled cartilage bioreactor system: A – Standard incubator; B – Culture tray; C – Peristaltic pump; D – Medium reservoir; E – Medium inlet and outlet ports; F – Stepper motors; G – PLC control box; H – Stepper motor drivers; I – Power supply. (Yusoff, 2011)

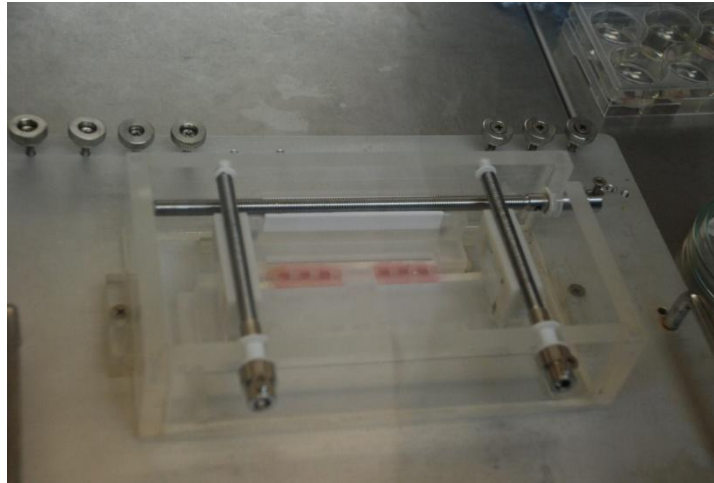

Figure 3.7 Once the agarose-chondrocyte constructs were transferred to the test rig, SS columns were fixed to the direct and shear compressive brackets upon removal of the handle. These steps need to be done carefully to avoid any movement of the constructs.

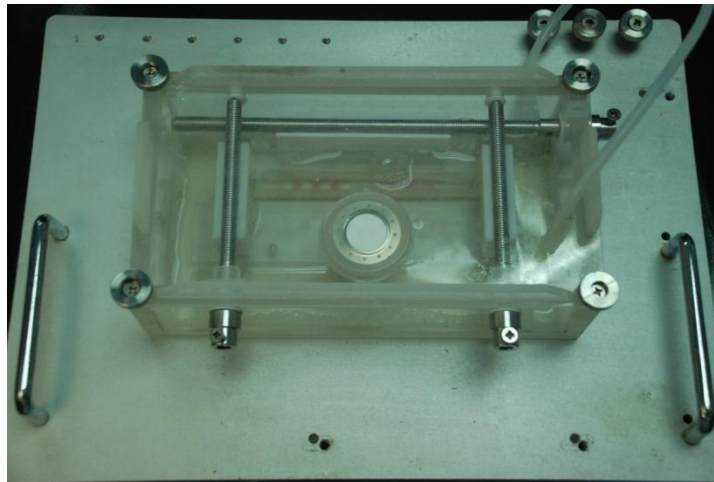

Figure 3.8 Culture medium was poured into the test rig, making sure all constructs were fully immersed. Prior to the transportation of test rig into the incubator, the rig was covered with a lid to ensure sterility. Bug filter was integrated to the test rig making sure of gas exchange going in and out of the test rig.

Then, each SS column was fixed to a stepper motor, controlled by the programmable logic controller (PLC) unit. 150 ml DMEM+20% FBS was poured into the system, to ensure that all cell-agarose constructs were fully immersed.

3.4. Biochemical Assays

3.4.1. Digest of Chondrocyte-Agarose Constructs

Once the mechanical loading had ended, the SS columns were removed from the stepper motor and the test rig was taken into the laminar hood for removal of agarose constructs for further characterization and analysis. Control groups were also removed from the incubator. Each sample was carefully separated from the porous glass platens using a sterile spatula.

Prior to the GAG and DNA quantification, the chondrocyte-agarose constructs were digested.

In a small bijou tube containing one construct, 1 ml of digest buffer was added and kept for one hour in 70°C oven. Prior to adding 10 U.ml⁻¹ of agarase and 2.8 U.ml⁻¹ of papain to each construct, the sample was cooled to about 37°C. After an overnight agarase digestion, the sample needed to undergo further digestion at 60°C for one hour (Chowdury et al., 2003).

Portions of the digest were centrifuged for 10000g for 5 minutes at room temperature. The suspension was analyzed for DNA content using Hoechst 33258 dye with calf thymus DNA as a standard. Total DNA was used as a baseline for GAG synthesis.

GAG content was assessed immediately to prevent the agarose digest from re-solidifying. If needed, the melted constructs could be stored at -20°C. Total synthesis of GAG is the sum of the deposition into the matrix and the release into the medium.

3.4.2. Deoxyribonucleic (DNA) content

Hoescht 33258 Assay

Generally, DNA content is used to estimate tissue cellularity and Hoescht 33258 is often used to measure DNA (McGowan, Kurtis, Lottman, Watson, & Sah, 2002; M. R. Urban, Fermor, Lee, & Urban, 1998). Hoescht 33258 is a DNA-specific dye that fluoresces on binding to DNA. Hoescht 33258 consists of two consecutive benzimidazole rings, with a phenolic and an N-methyl-piperizine group at either end of the elongated molecule (Teng, Usman, Frederick, & Wang, 1988). This dye binds to the AT-rich region of the double helical DNA (Pitha, 1978; Teng et al., 1988). The use of this type of dye is preferable as it has low affinity to RNA and other proteins that might influence the reading of DNA content (Mülhardt, 2007).

The Hoescht 33258 assay protocol was adapted from Hoemann (2004). 2 mg Hoechst 33258 was added into each ml of dH₂O to make the Hoechst stock solution and stored at 4°C in a light-tight bottle. Just before use, a working solution was made by dilution of the 10000x stock solution to 0.1µg/ml in TEN buffer (10mM Tris-HCL, 1mM EDTA and 100mM NaCl, pH 7.5). The working solution was held in and dispensed from a light-tight container.

Calf Thymus DNA Standard

The DNA standard serves as a one-point reference for DNA quantifications. DNA standard isolated from the nuclei of calf thymus cells are mainly utilized for plant and animal DNA measurement as they are double-stranded and highly polymerized with 58% AT content (Y.-J. Kim, Sah, Doong, & Grodzinsky, 1988; Mülhardt, 2007).

Calf thymus DNA (D1501, Sigma-Aldrich, Malaysia) was dissolved in PBE buffer (100mM phosphate buffer, 10mM EDTA, pH 6.5) to 50µg/ml concentration, stored as 100µL frozen aliquots at -20°C. A serial double dilution of standard was anticipated by diluting the 0.5mg/ml stock solution of calf thymus DNA standard to 25 to 0.781 µg/ml in PBE buffer.

A standard curve was generated prior to the DNA measurement using serial dilution of calf thymus DNA standard. This was done to validate the standard. PBE buffer and Hoechst 33258 assay was used as the blank. A microplate fluorometer (FLUOstar Optima, BMG Labtech, Malaysia) was used to read the fluorescence level at 355 nm excitation and 460 nm emission (Hoemann, 2004; McGowan et al., 2002). Using a 96-well plate (TPP, Malaysia), the first two columns were filled with 10 µl PBE buffer for blanks, while 10µl of each samples was pipetted into each well as triplicates. 200µl working solution was dispensed into each well prior to the fluorescence reading, using the multi-channel pipette.

3.4.3. Synthesis of Sulphated Glycosaminoglycans

DMB Assay

Dimethylmethylene blue (DMB) is a dye that produces metachromasia upon cationic dye binding to sulphate and carboxyl groups present in GAG chains. Metachromasia or colour change from blue to purple is produced by pH and salt concentration of the dye (Enobakhare, Bader, & Lee, 1996; Goldberg & Kolibas, 1990).

1,9 dimethylmethylene blue (DMB) assay was prepared prior to glycosaminoglycan quantification. 0.016 g DMB (Sigma-Aldrich, Malaysia) was dissolved in 5.0ml 99.7%

Ethanol (Sigma-Aldrich, Malaysia) in a foil-wrapped capped glass scintillation vial. A magnetic stirrer (WiseStir MSH10, Daihan Sci., Malaysia) was used to ensure mixing.

In another clean bottle, 2.00 g of sodium formate was dissolved in 950mL of autoclaved double-distilled H₂O (R.W. Farndale, Sayers, & Barrett, 1982). The DMB solution was mixed with the NaCl-glycine solution. The DMB solution residual was rinsed with 200µL ethanol. Concentrated formic acid (99%) was used to reach pH 3.00 (Enobakhare et al., 1996). The solution was topped up with ddH₂O until 1L. The assay was then stored at room temperature in a foil-covered bottle.

Chondroitin-4-sulphate standard

GAG content in the samples was quantified by comparing the obtained fluorescence values with those of a curve generated from standards of known amounts of chondroitin sulphate.

Besides DMB assay, bovine chondroitin-4-sulphate (C6737, Sigma-Aldrich, Malaysia) was used as the reference solution. The chondroitin-4-sulphate was reconstituted in dH₂O at a concentration of 0.5mg/ml, stored in the -20°C freezer in 500µL aliquots.

Upon usage, the chondroitin-4-sulphate was thawed and a vortex mixer (VTX 3000L, LMS Scientific, Malaysia) was used to ensure good distribution of the solution. A serial double dilution of standard was anticipated by diluting the 0.5mg/ml stock solution of bovine chondroitin-4-sulphate standard to 25 to 0.781 µg/ml.

A standard curve was generated prior to the GAG measurement using serial dilution of chondroitin-4-sulphate standard. This was done to validate the chondroitin-4-sulphate

standard. dH₂O and DMB assay was used as the blank. Fluorometer microplate reader (FLUOstar Optima, BMG Labtech, Malaysia) was used to read the absorbance level. Values of OD₅₂₀-OD₅₉₀ should be in the range of 0.65 to 0.8 to validate the standard.

Absorbance Reading of the Sample Post-Loading

The microplate fluorometer reader was set to read the absorbance between the wavelengths of 520 to 590 nm (Yun & Moon, 2008). 10µL of each samples and standards were pipetted into the 96-well plate as illustrated in Table 3.4. Eppendorf repeat pipetor with a 5.0mL tip was used to dispense 250µL of DMB assay into each well.

Table 3.4 Layout of the microplate. S wells are filled with chondroitin-4 sulfate at stated concentration, while X wells are filled with samples. All wells including the blank ones are filled with DMB assay.

	1	2	3	4	5	6	7	8	9	10	11	12
A	Blank	S1	S2	S3	S4	S5	S6	Blank				
B	Blank	S1	S2	S3	S4	S5	S6	Blank				
C	X1	X1	X1	X7	X7	X7	X13	X13	X13			
D	X2	X2	X2	X8	X8	X8	X14	X14	X14			
E	X3	X3	X3	X9	X9	X9	X15	X15	X15			
F	X4	X4	X4	X10	X10	X10	X16	X16	X16			
G	X5	X5	X5	X11	X11	X11	X17	X17	X17			
H	X6	X6	X6	X12	X12	X12	X18	X18	X18			

3.5. Statistical Analysis

A one-way analysis of variance (ANOVA) was used to compare the cell yield and cell viability under the influence of different types of collagenase. In all cases, $p < 0.05$ was used to indicate statistical significance. A two-sample t-test was run to determine validity of digestion in different concentration of enzymes.

A two-way analysis of variance (ANOVA) considering types of waveforms (trapezoidal or sinusoidal) or 24 hours pre-culturing effect were utilised to determine the statistical significance of the data analyzed in terms of uniaxial or biaxial mechanical loading.

The two-way ANOVA was also computed to obtain information to assess the main effect and interaction effect between two independent variables. When there is a main effect, one independent variable has a significant effect on the dependent variable, regardless of the condition of the other independent variable. While, when there is an interaction effect, the lines in the line graph connecting the group means are not parallel. The lines cross at some point, either within the graph or, if the lines were to be extended, someplace off the graph (Johnson & Christensen, 2010; Rubin, 2009).

Chapter 4. Study 1 (Chondrocyte Isolation)

4.1. Introduction

Limitations to the natural repair process of cartilage have motivated the development of tissue-engineered constructs for cartilage replacement. These strategies typically involve the incorporation of the tedious process of isolating chondrocytes through various protocols. Primary cell cultures of articular chondrocytes is typically isolated from mice, rat, rabbit and sometimes bigger size animal such as porcine, cattle and even human (Sabatini, Pastoureau, Ceuninck, Thirion, & Berenbaum, 2004). In our current study, AC from the calf joint has been used for several reasons. Bigger sized animals are more preferable due to the larger area of AC available to be harvested, so more chondrocytes can be yielded when calf joints are used. Further, for religious reasons, bovine joints are preferred to porcine joints. Moreover, the mechano-physical conditions of the calf joint approximate well to the human joint (Abbot, Levine, & Mow, 2003; Chen, Bae, Schinagl, & Sah, 2001; Federica, Giancarlo, Francesca, Giuseppe, & Gabriele, 2004; Jurvelin, Buschmann, & Hunziker, 1997).

Currently, there is not yet any paper published that investigate the optimization of cell isolation from the articular cartilage of *Bos indicus*, a species of cow raised in Malaysia (in contrast to *Bos taurus*, typically reared in temperate climates). It is believed that differences between genetic and environmental influences of the respective sources, including the effect of diet and size of animal species affect the content of the tissue. A local source is important as cartilage needs to be extracted within a few hours of slaughter (Barbero & Martin, 2007; Giannoni & Cancedda, 2006; Thonney, 2005).

A secondary objective of this research is to optimize cell isolation from the primary tissue of AC from local bovine sources, without risking the viability of the cells. In order to obtain a higher number of viable cells with fewer contaminating cells, the isolation procedures need to be optimized. This chapter describes an optimised method of chondrocyte isolation from the bovine joint. The chapter explains in detail the parameters of digestion enzymes used in this study. Isolated chondrocytes with high counts of viable cells will be used in further studies involving the effects of mechanical stimulation on the proliferation and differentiation of chondrocytes.

In this particular chapter, the study on isolation of local bovine articular chondrocytes was initially conducted following the protocol of Chowdury et al. (2003) and Pinguan-Murphy et al. (2005) who utilized a two-stage digestion using protease and collagenase type-XI. However, cell yield was insufficient, at $2.99 \times 10^5 \pm 1.71$ cells per ml. An initial alteration was made to the digestion protocol in order to get a higher cell yield, by increasing the concentration of collagenase type-XI from 100 to 800 U.ml⁻¹ (results not shown). Even though cell yield then increased by about 49%, cell viability reduced from 90% to 45%.

4.2. Methods

Primary cells from AC were extracted from the bovine metacarpal-phalangeal joint. The chondrocytes were obtained using the protocol as given in Section 3.1.3.

Different Type of Collagenase

After pre-digestion, the cartilage fragments were immersed to collagenase. Either Type-Ia, type-II or type-XI collagenase was reconstituted using DMEM + 20% FBS to

an activity of 200 U.ml⁻¹. This solution was then filtered through a 0.22 µm pore cellulose-acetate filter, aliquoted into 20 ml samples and stored at -20°C.

Different Concentration of Collagenase Type II

The viability and cell yield were compared using two different concentrations of collagenase; 100 and 200 U.ml⁻¹.

Incubation Duration

The duration of collagenase exposure to cartilage extracts were examined. These durations were 14, 15 and 16 hours.

Statistical Analysis

As mentioned in Section 3.5, statistical analysis was carried out with single factor ANOVA. A two-sample t-test was used to determine the effect of digestion by different concentrations of enzymes.

4.3. Results

4.3.1. Effect of Collagenase Types on Cell Yield and Viability

The effect of using different types of collagenase for chondrocytes isolation is shown in Figure 4.1. There is evidence of the effect of collagenase type on cell yield (Figure 4.1a) and viability (Figure 4.1b). There is a statistically significant difference between the type of collagenase in terms of cell yield obtained; collagenase type I yielded fewer cells than collagenase type XI or Collagenase type II ($p < 0.05$). Collagenase type II digest yielded the highest total cell count (14.2×10^6 cells.ml⁻¹) and the highest viability (97.5%).

4.3.2. Effect of Reducing the Concentration of Collagenase Type-II

Reducing the concentration of type-II collagenase did not improve cell yield. Higher concentrations of the enzyme (200 U.ml^{-1}) yielded more than three times the cells that at a concentration of 100 U.ml^{-1} ($P < 0.05$) (Figure 4.2a). A lower concentration of collagenase also reduced the cell viability (Figure 4.2b).

4.3.3. Effect of Collagenase Incubation Periods on Cell Yield and Viability

Based on the results of Section 4.3.1 and Section 4.3.2, collagenase type II at a concentration of 200 U.ml^{-1} was applied, to study the effect of collagenase concentration. Cell yield and cell viability increased with digestion time (refer to Figure 4.3). The viability of cells harvested after 16 hours digestion was 97.5% (refer to Figure 4.3b), significantly higher than after 14 and 15 hours digestion, 77.5% and 77.4% respectively.

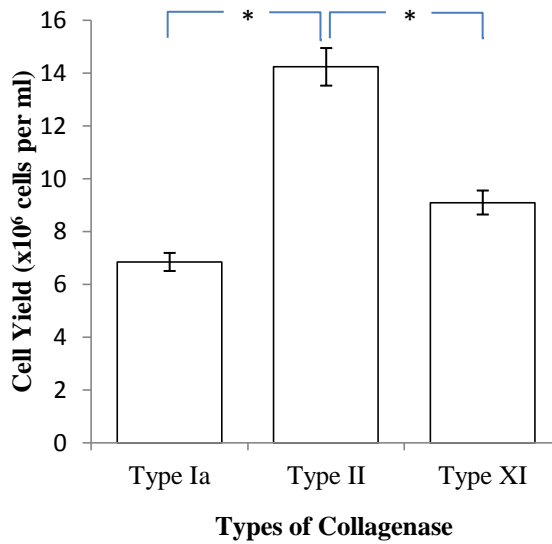

a)

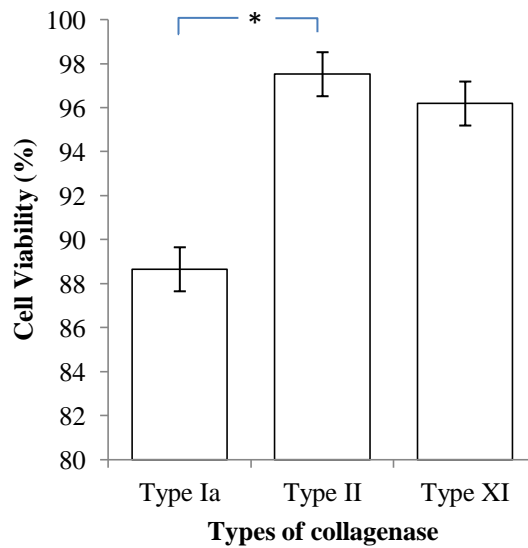

b)

Figure 4.1 a) Cell yield with different types of collagenase. (*) denotes significantly different ($p < 0.05$) cell yield versus all types of collagenases. (b) Cell viability with different types of collagenase. (*) denotes cell viability with significantly different $p < 0.05$ versus collagenase Type Ia, while the difference of cell viability collagenase Type II and Type XI is insignificant. All values shown as mean \pm standard error of the mean (SEM) ($n=30$).

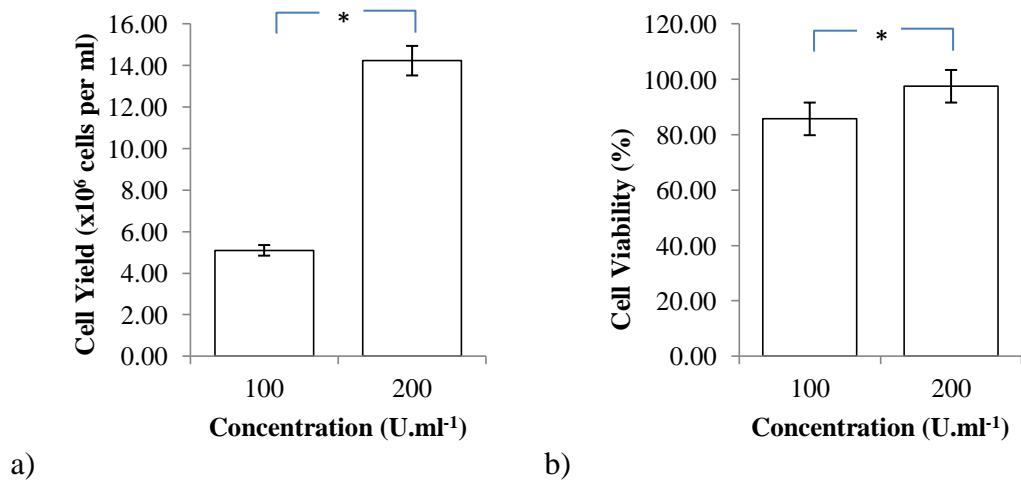

Figure 4.2 (a) showing cell yield from digestion using concentration of either 100 or 200 U.ml⁻¹. Higher concentration produced significantly higher cell yield. Cell viability for cells using reduced concentration has shown a significant decrease (b). (*) shows significant value of ($p < 0.05$) by ANOVA and error bars showing standard error of the mean.

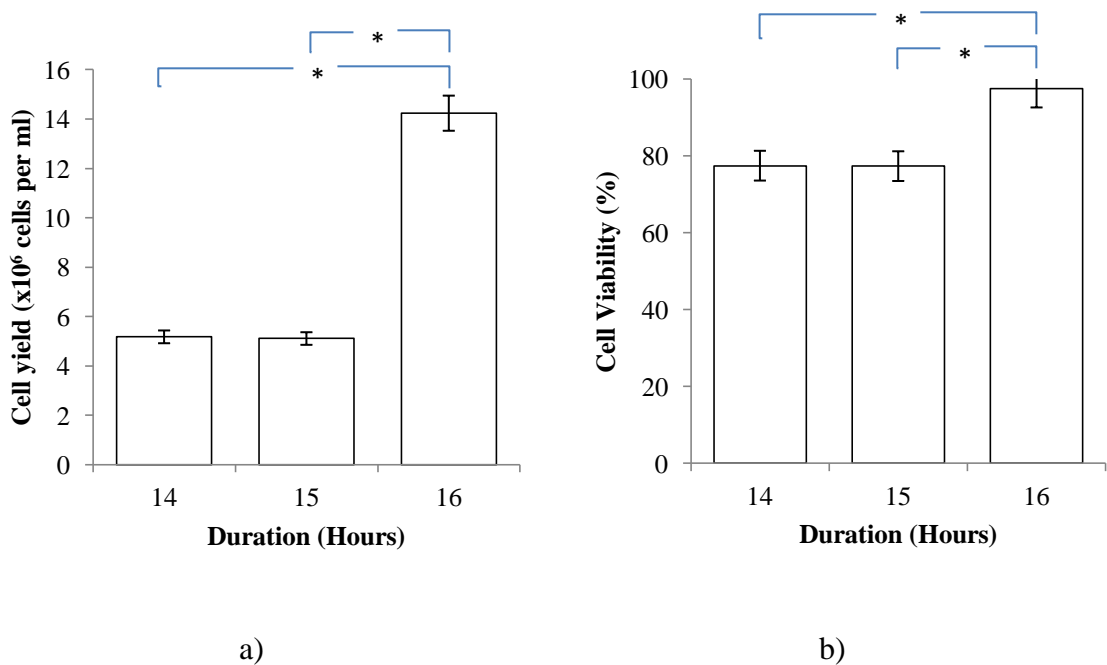

Figure 4.3 Influence of digestion time on cell yield (a) and cell viability (b). (*) indicates that single-factor ANOVA test shows that cell yield and cell viability of 16 hours versus 15 hours and 14 hours is highly significant ($p < 0.05$). All values shown are mean values for $n=30$. Error bars represent standard error of the mean.

This study has shown optimized chondrocyte isolation protocol is as Table 4.1.

Table 4.1 Optimized chondrocyte isolation protocol.

Pre-digestion (not included in study)			Overnight digestion		
Enzyme	Concentration (U/ml)	Time (min)	Enzyme (Collagenase)	Concentration (U/ml)	Time (min)
Protease	20	60	Type-II	200	960

4.4. Discussion

The chondrocyte isolation procedure is optimised to obtain a high number of viable cells. Chondrocytes that have been isolated are essential to ensure sufficient viable cells to be seeded in hydrogel constructs for further studies involving the physiology and biomechanics of chondrocytes. Initially, a chondrocyte isolation protocol used within Bader's group and elsewhere (Bryant, Chowdhury, Lee, Bader, & Anseth, 2004; Chowdury et al., 2003; D. Lee et al., 2000; Roberts, Knight, Lee, & Bader, 2001) that uses collagenase type-XI was adopted in our laboratory. However, we believe that for local Malaysian bovine tissues (*Bos indicus*), the use of collagenase type-II is preferential.

Having highly complex composition and architecture, the protein crosslinking and microstructure of cartilage is poorly understood and researchers do not have a standard method of isolating chondrocytes from the ECM. Isolation of locally sourced bovine chondrocytes has been assessed using different types of collagenase, using protease as the pre-digestion enzyme. Protease partially degrades PG to expose the collagen fibres to collagenase for further digestion. This additional step decreases the exposure time and overall digestion time (Hayman et al., 2006). There is also a literature that added

hyaluronidase into protease in the pre-digestion stage. Hyaluronidase digests hyaluronan, a non-sulphated glycosaminoglycan that aids proliferation and migration of chondrocytes (Hansen et al., 2001).

About half of the dry weight of cartilage is collagen. Collagen is an insoluble fibrous protein in the ECM that serves as a framework or internal scaffolding. Collagen needs to be degraded in order to break the ECM. On the grounds that collagen is fully hydroxylated and in a triple helical structure, collagen is insusceptible to most proteases except for collagenase, an enzyme that belongs to the family of metalloproteinases or MMPs. Collagenolysis begins with cleavage of the collagenase enzyme at the triple-helical molecules about three-quarters of the molecular length from the amino-terminal end at neutral pH (Stockwell, 1979).

Different types of collagenase act to digest the corresponding type of collagen in the collagenase network of cartilage, resulting in the release of the chondrocytes. Bovine cartilage, as in other mammals has core fibrillar network of cross-linked copolymer of collagens II, IX and XI, with type II collagen being the principal molecular component (Eyre, 2001). Thus, when Collagenase type II was used, highest cell yield was obtained. Collagenase type II cleaves the most abundant type of collagen in cartilage; type-II collagen. This type of collagen has major interactions with water that is attracted to the carbohydrate group.

Cell yield was found to increase as the isolation process was subjected to longer enzymatic duration. A longer enzymatic duration enabled a more complete digestion of the collagenous network of bovine articular cartilage, thus more chondrocytes were released to contribute to a higher cell yield.

As for the viability of cells, a value higher than 90% is considered excellent. It was also found that 200 U.ml⁻¹ of collagenase yielded a higher cell count than cartilage that was exposed to 100 U.ml⁻¹ of collagenase. This showed that a higher concentration of enzyme yields a higher number of cells.

On the other hand, the use of a syringe and needle to detach and distribute the cells in the suspension increased the cell yield up to 74%. This additional step has contributed towards the disaggregation of cells that tend to adhere to each other. Viable cells tend to adhere to other cells through integrins and cadherins. For cell counting purposes, the cells need to be detached before the counting. Results of the cell yield tests show that there is a 4-fold increase of cells. A single chondrocyte diameter is measured as about 9µm (Nguyen et al., 2010). However, our group has observed that an application of syringe needle smaller than 21 gauge (19.5 µm) led to higher cell death.

It is evidently shown that dedifferentiation of cartilage cells occurs under monolayer culture (Frohlich et al., 2007). Instead of expressing type II collagen which is cartilage-specific collagen, cartilage cells tend to express types I and III collagen, when the cells were dismantled from their three-dimensional environment (Goldring, Sandell, Stephenson, & Krane, 1986; Saadeh et al., 1999). Other studies found cartilage cells in 3D culture systems with certain growth factors do not change its phenotypic properties (Benya & Shaffer, 1982; Bonaventure et al., 1994; Naumann et al., 2004; van Osch, van der Veen, & Verwoerd-Verhoef, 2001). Subsequent to this optimised isolation protocol and 3D constructs seeding, further study should be done to determine its morphology and expression of cartilage specific genes such as collagen type II and aggrecan.

Metabolism of cells will result in an increased carbon dioxide concentration, thus will change the pH of the cell surroundings. In our study, culture medium needs to be maintained at a neutral pH as the enzymes work best in that level of pH. In cell culture, pH can be maintained by the zwitterionic organic chemical buffering agent, 4-(2-Hydroxyethyl)piperazine-1-ethanesulfonic acid (HEPES) (Baicu & Taylor, 2002).

Besides supplying nitrogen for molecular transportation purposes, the amino acid L-glutamine contained in culture medium, can be used to provide energy to the rapidly dividing cells. While penicillin combined with streptomycin acts as an antibacterial agent, ascorbic acid is known to participate in the hydroxylation of proline and lysine. The addition of $-OH$ is essential to stabilize the crosslinking of the collagen fibrils (Giannoni & Cancedda, 2006).

Chapter 5. Study 2 (Effects of Dynamic Uniaxial Loading on Cellularity and ECM Production)

5.1. Introduction

As illustrated in Table 2.3, there are multiple studies that assess the influence of mechanical loading on cartilage. Physiologically, cartilage experiences a complex array of physical stimuli due to interstitial compressive, tensile and shear stresses within its ECM (Mankin et al., 1994).

This chapter will generally describe the experimental work that has been undertaken to examine the influence of uniaxial mechanical compression on chondrocytes. The chapter starts with a section describing the experimental model of isolated bovine articular chondrocytes seeded into a 4% agarose gel. Then, the model will be integrated to the test-rig. In this chapter, the test rig will be used to deliver direct compressive strain to the agarose-chondrocyte specimens.

5.1.1. With and without 24 hours preculture

Other studies have also indicated a role for a pre-culturing period prior to exposure of any mechanical loading to chondrocytes (M. Buschmann et al., 1995; Knight et al., 1998). This study will evaluate the need of pre-culturing for chondrocytes before being subjected to the uniaxial loading (10% direct compressive + 0% shear compressive strains).

5.2. Methods

5.2.1. Effects of Dynamic Uniaxial Loading on Cellularity and ECM Production

Upon seeding the constructs with isolated chondrocytes and setting up the test rig as depicted in section 3.2.1. The cell-agarose constructs were subjected to 10% dynamic direct compression at 1 Hz (sinusoidal) for 48 hours, intermittently (12 hours on; 12 hours off). Trapezoidal or sinusoidal waveform dynamic direct compression was applied by one of two bioreactors for a period of 12 hours. The bioreactors then set to rest and restarted on the next day (t=24 hours). Throughout the experiment, all loaded and unstrained samples (control group) were maintained in a 37°C, 5% humidity controlled environment.

5.2.2. Effects of 24 Hour Pre-Culture Prior to Dynamic Uniaxial Loading

Section 5.2.1 explained protocols utilised to deliver uniaxial loading to agarose three-dimension scaffolds that have been seeded with isolated chondrocytes. This part of the study integrates a 24 hour pre-culture period into the experimental protocol. Upon seeding and moulding, the six agarose constructs in each bioreactor cassette were left under free-swelling conditions for 24 hours in the 37°C, 5% humidity controlled incubator. The bioreactor then commenced delivery of uniaxial (trapezoidal/sinusoidal) compression as previously described. A control group is described as 6 samples kept on a culture plate, unstrained, within the bioreactor for a total of 72 hours (refer to Section 3.2.2).

5.3. Results

5.3.1. Effects of Dynamic Uniaxial Loading on Cellularity and ECM Production

The influences of trapezoidal and sinusoidal uniaxial strain on DNA content in cell-agarose digests are presented in Figure 5.1 (a). DNA values are normalised to unstrained control levels. 1 Hz dynamic sinusoidal strain inhibited cell proliferation by 20% ($p < 0.05$), while trapezoidal strain showing increase of DNA content in comparison to the unstrained samples, by 20% ($p < 0.05$), across 48 samples. The samples in this data set were not pre-cultured; instead they were immediately exposed to uniaxial loading upon seeding with chondrocytes.

Mean sulphated GAG incorporation by chondrocytes after being loaded in sinusoidal uniaxial regime averaged $1.137 \mu\text{g}/\mu\text{g}$ in medium and $1.004 \mu\text{g}/\mu\text{g}$ in construct respectively. The mean values of GAG content for all samples using DNA content as baselines are summarised in Table 5.1, and Figure 5.1(b) depicting these values normalised to unstrained control levels (100%).

Table 5.1 Absolute values for GAG content in medium, constructs and total GAG synthesis, with DNA content as baselines by chondrocyte/agarose constructs subjected to various waveform uniaxial loading. The average values are taken from 24 samples from four separate experiments. Errors shown are standard error of mean.

<i>Loading Regime</i>	$GAG_{medium}/DNA (\mu\text{g}/\mu\text{g})$	$GAG_{construct}/DNA (\mu\text{g}/\mu\text{g})$	$GAG_{total}/DNA (\mu\text{g}/\mu\text{g})$
Trapezoidal	0.598 ± 0.035	0.691 ± 0.013	1.289 ± 0.045
Sinusoidal	1.137 ± 0.079	1.004 ± 0.028	2.141 ± 0.139
Unstrained	0.196 ± 0.029	0.231 ± 0.048	0.427 ± 0.137

5.3.2. The Effects of 24 Hours Pre-Culture Prior to Dynamic Uniaxial Loading

After overnight digestion, 8 million cells.ml⁻¹ were mixed into 8% agarose and moulded for the bioreactor. Upon setting up the specimens into the bioreactor, uncompressed control and dynamically loaded specimens were cultured for 24 hours before the actual loading period. After the 48 hours loading regime ended, the specimens were immediately removed, underwent papain/agarase digestion, and were measured for DNA content (Figure 5.2a) and PG synthesis (Figure 5.2b).

No significant changes can be seen in DNA content of samples loaded in a sinusoidal manner compared to unstrained control samples ($p>0.05$). On the other hand, a 35% increase of DNA content was observed in samples loaded in trapezoidal manner over control.

For proteoglycan synthesis, one-way ANOVA indicates p value of less than 0.05 between the higher values of sGAG incorporation within chondrocyte seeded agarose scaffolds upon being exposed to compressive strain; and control unstrained samples. A higher proteoglycans production can be observed from the medium contained in a 1 Hz sinusoidally and uniaxially loaded specimen - twice as much as the total proteoglycans measured from both medium and digested constructs that were exposed under trapezoidal uniaxial loading. Distinguished difference between GAG productions of samples being loaded in sinusoidal waveform was also contributed by high concentration of GAG detected within the constructs.

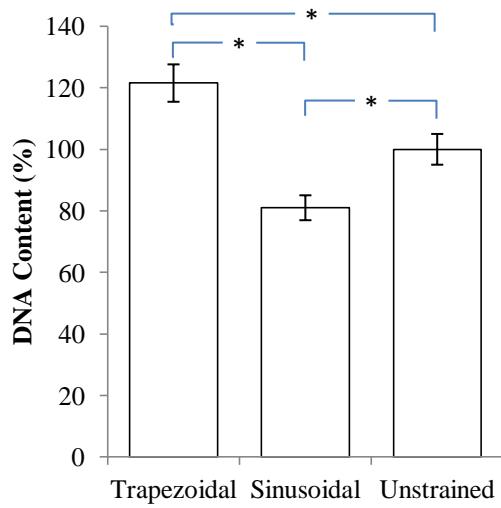

(a)

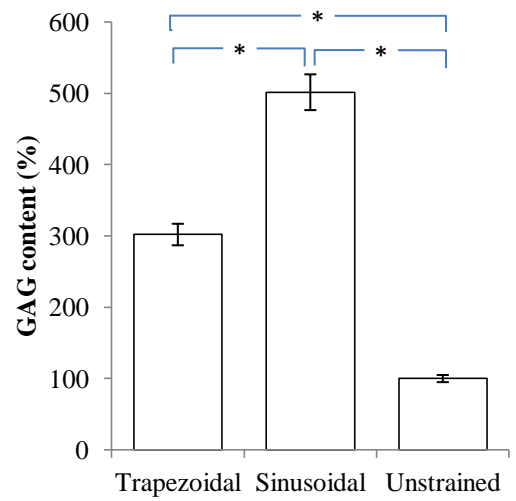

(b)

Figure 5.1 The percentage change from unstrained control values for a) DNA content and b) GAG content in chondrocyte-agarose digest upon subjected to 10% gross compressive strain in trapezoidal and sinusoidal waveform for 48 hours. Each value represents the mean and standard error of 24 replicates, normalised to the control unstrained samples (100%). One-way ANOVA indicate differences between trapezoidal, sinusoidal and unstrained control samples as (*) $p < 0.05$.

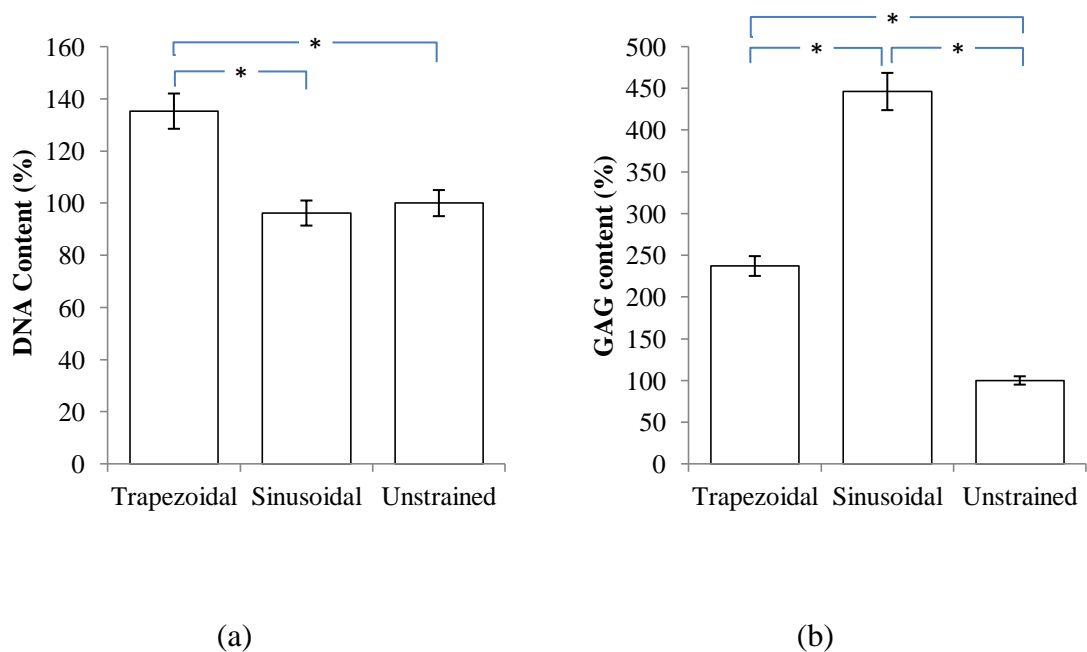

Figure 5.2 Evaluation of the 24 hours pre-culture effect on a) DNA content and b) proteoglycan production by chondrocytes encapsulated in agarose scaffolds. Upon seeding, the chondrocytes-agarose constructs were left free swelling within the incubator for 24 hours, before being exposed to dynamic 10% direct compressive strain for 48 hours. Data are given by mean and standard error of mean (n=24) with (*)p<0.05. The data are normalised to the control unstrained specimens to eliminate other independent variables.

5.4. Discussion

Dynamic mechanical load is essential to induce cell proliferation and cell metabolism. Our finding is parallel to other scientific studies that see dynamic mechanical load as somehow stimulating chondrocyte metabolism through increased GAG production compared to static compression or unstrained specimens (M. Buschmann et al., 1995; Chowdury et al., 2003; Davisson et al., 2002; RL Mauck et al., 2003; Shelton et al., 2003).

In another study, 5% amplitude of sawtooth compressive load was given to chondrocytes seeded in scaffold. It was found that more s-GAG incorporation was observed on chondrocytes that was given 50% offset compression at 0.1 Hz over 0.001 Hz. (Davisson et al., 2002). In addition, Shelton et al. found dynamic strain at 0.3 Hz

produces a significant inhibition in GAG synthesis over unstrained control samples (2003). Even though a higher frequency increases the rate of fluid flow, the effective area will be smaller (Sah et al., 1989).

There is a slight reduction of DNA measured in papain-digested chondrocyte-agarose constructs upon exposure to sinusoidal 10% load at a frequency of 1 Hz. The same observation was seen by Waldman et al., which DNA level of chondrocytes, that were loaded at 1-3% amplitude intermittently, decreased (2007; 2003). This phenomena is explained by the s-cycle completion of cells (Huselstein et al., 2006) (refer to Section 7.4).

In terms of the dynamic load waveforms, two 12-hour periods of sinusoidal loading seem to have a stimulatory effect on the production of GAG indicating metabolic activity of cells designed to produce new ECM. As reported by Chowdury et al.(2003), 86400 cycles of 15% amplitude of dynamic compressive loading applied at 1 Hz in two 12 hour blocks provided a greater stimulation that the same number of cycles applied in one 24 hour block. New PG production is essential for cell survival, as ECM provides fundamental role in signal transduction. The resting period in the middle of the load exposure benefits the cells by allowing them to restore their mechano-sensitivity.

As explained previously, chondrocytes exposed to sinusoidal dynamic uniaxial mechanical loading shows a DNA level reduction. This predicament, however, has been solved by integrating a 24 hour pre-culture period to the chondrocyte-agarose constructs prior to the mechanical load. Pre-culturing not only shows no significant reduction of DNA concentration in the papain-digested chondrocytes-agarose constructs exposed to sinusoidal load, but it also increases DNA concentration of constructs exposed to

trapezoidal load up to 30%. In a study carried out by Davisson et al., the chondrocytes seeded scaffolds were left free swelling for up to three weeks prior to load exposure (Davisson et al., 2002).

Throughout the data analysis, all measurements were normalized to unstrained control samples to eliminate other external factors such as medium that might affect cell proliferation and GAG production.

As a summary, the findings from this chapter show that dynamic mechanical loading has potential to facilitate the culture of functional tissues in vitro, by modulating the proliferation and metabolism in a manner dependent on the nature of the loading regime applied.

Chapter 6. Study 3 (Effects of Dynamic Biaxial Loading on Cellularity and ECM Production)

6.1. Introduction

Mechanical forces and deformations are sensed by cells and turned into biochemical signals. This evolution is essential in regulating chondrocyte function; both in metabolic and catabolic modus operandi. The main objective of this current study is to see the influence of biaxial loading on chondrocytes.

This chapter will be outlined as the previous chapter, describing experimental works that have been used throughout this thesis. While the previous chapter is on the influence of uniaxial mechanical strain on chondrocytes, this current chapter will describe experimental works to see the influence of biaxial mechanical strain on chondrocytes. The chondrocyte-agarose constructs will be integrated into the bioreactor. The test rig is designed to be capable of delivering both direct and/nor shear compressive strain(s) to the agarose-chondrocyte specimens.

6.1.1. With/ without preculture

Previous findings reported by Buschmann (1995) have shown pronounced response of chondrocytes to static and dynamic mechanical compressive loads when exposed at a later stage of culture. The effects of direct compressive load on chondrocyte metabolism appear to depend on the amount of pericellular matrix formed after a minimum of 1 day culture. Thus, the need of pre-culturing upon exposure to biaxial loading was also examined.

6.2. Methods

6.2.1. Effects of Dynamic Biaxial Loading on Cellularity and ECM Production

In the previous chapter, only two stepper motors arranged in parallel were used to deliver dynamic direct compression. In order to have the chondrocyte-agarose constructs loaded bi-axially, a third perpendicular motor was also used. This stepper motor drove the shear bracket (refer to Figure 3.6) at 1 Hz (sinusoidal) for 48 hours, intermittently (12 hours on; 12 hours off). The magnitude of shear strain was set at 1%, direct compression at 10%. The systems were set up as described in Section 3.3. Another bioreactor cassette was used to deliver trapezoidal biaxial intermittent loading at the same magnitude as the sinusoidal mechanical regime for two 12 hour periods of time for a total of 48 hours including two 12 hour resting periods. Throughout the experiment, all loaded and unstrained samples (refer to Section 3.2.2) were held in a 37°C, 5% humidity controlled environment. Unstrained samples were placed within the bioreactor and were used as the control group.

6.2.2. Effects of 24 Hours Pre-Culture Prior to Dynamic Biaxial Loading

In a second series of experiments, the loading protocol as described in Section 3.3, was initiated after an additional period during which the constructs were left under free swelling conditions for 24 hours in the 37°C, 5% humidity controlled environment. Cell-agarose constructs were subjected to 10% direct compression and 1% shear compression (sinusoidal) at a frequency of 1 Hz for a total of 48 hours, including two 12-hours resting periods as above (Section 6.2.1). Another set of experiments put the chondrocyte-agarose constructs under trapezoidal loading at the same magnitude as the sinusoidal loading for the same duration. The unstrained samples were used as a control

group. The control group was put in a 6-well plate and placed in the same incubator as the bioreactor throughout the experiment, including the 24 hour pre-culture period.

6.3. Results

6.3.1. Effects of Dynamic Biaxial Loading on Cellularity and ECM Production

Cell proliferation and PG synthesis were measured using calf thymus DNA and bovine chondroitin sulphate as standards (see Sections 3.4.2 and 3.4.3). While 1 Hz sinusoidal biaxial strain showed a significant inhibitory effect on cell proliferation (Figure 6.1a), this mechanical regime stimulates up to 7.5-fold production of proteoglycans (Figure 6.1b), marked by a high content of sulphated glycosaminoglycans in both the medium and the constructs (Table 6.1). It also shows that when constructs were loaded in a biaxial manner, PG content in constructs was seen to be double that in the medium. The values given are significantly different (one-way ANOVA test, $P < 0.05$ among trapezoidal, sinusoidal and unstrained samples). The values have been normalized to control unstrained samples, aiding batch-to-batch comparison.

Table 6.1 Absolute values for GAG content in medium, constructs and total GAG synthesis, with DNA content as baselines by chondrocyte/agarose constructs subjected to various waveform biaxial loading. The average values are taken from 24 samples from four separate experiments.

<i>Loading Regime</i>	GAG_{medium}/DNA ($\mu\text{g}/\mu\text{g}$)	$GAG_{constructs}/DNA$ ($\mu\text{g}/\mu\text{g}$)	GAG_{total}/DNA ($\mu\text{g}/\mu\text{g}$)
Trapezoidal	0.804 ± 0.121	1.513 ± 0.101	2.316 ± 0.321
Sinusoidal	1.907 ± 0.501	2.784 ± 0.194	4.691 ± 0.375
Unstrained	0.301 ± 0.023	0.313 ± 0.038	0.614 ± 0.040

6.3.2. The Effects of 24 Hours Pre-Culture Prior to Dynamic Biaxial Loading

This set of experiments applied the same mechanical regime as Section 6.2.1. However, a 24-hours pre-culture period was integrated into the protocol in an effort to ascertain the effect of pre-culturing on chondrocytes seeded in agarose prior to being exposed to dynamic direct and shear compressive strains.

Figure 6.2 (a) shows DNA content in samples loaded in a trapezoidal manner 10% higher than the unstrained samples, while those loaded in a sinusoidal manner were reduced by 15% from the value given by the unstrained control samples ($p < 0.05$).

At 10% direct compressive strain (equivalent to gross construct deformation of 0.5 mm) and 1% shear compressive strain (equivalent to gross construct shear deformation of 0.05mm), this loading has shown a stimulatory effect on chondrocytes causing them to produce more GAG. When the chondrocyte-agarose constructs were loaded at a frequency of 1 Hz under a sinusoidal waveform, the cells seemed to produce a 2.5-fold increase in PG compared to constructs loaded in a trapezoidal manner. Table 6.2 depicts values of PG measured from the medium, and from digested constructs, normalised to values measured from the medium and unstrained digested constructs.

Table 6.2 Absolute values for GAG content in medium, constructs and total GAG synthesis, with DNA content as baselines by chondrocyte/agarose constructs subjected to various waveform biaxial loading. The average values are taken from 24 samples from four separate experiments. All samples were pre-cultured for 24 hours before loading.

<i>Loading Regime</i>	GAG_{medium}/DNA ($\mu g/\mu g$)	$GAG_{constructs}/DNA$ ($\mu g/\mu g$)	GAG_{total}/DNA ($\mu g/\mu g$)
Trapezoidal	0.796 ± 0.009	1.119 ± 0.015	1.915 ± 0.033
Sinusoidal	2.374 ± 0.092	2.763 ± 0.065	5.136 ± 0.283
Unstrained	0.266 ± 0.004	0.489 ± 0.011	0.755 ± 0.016

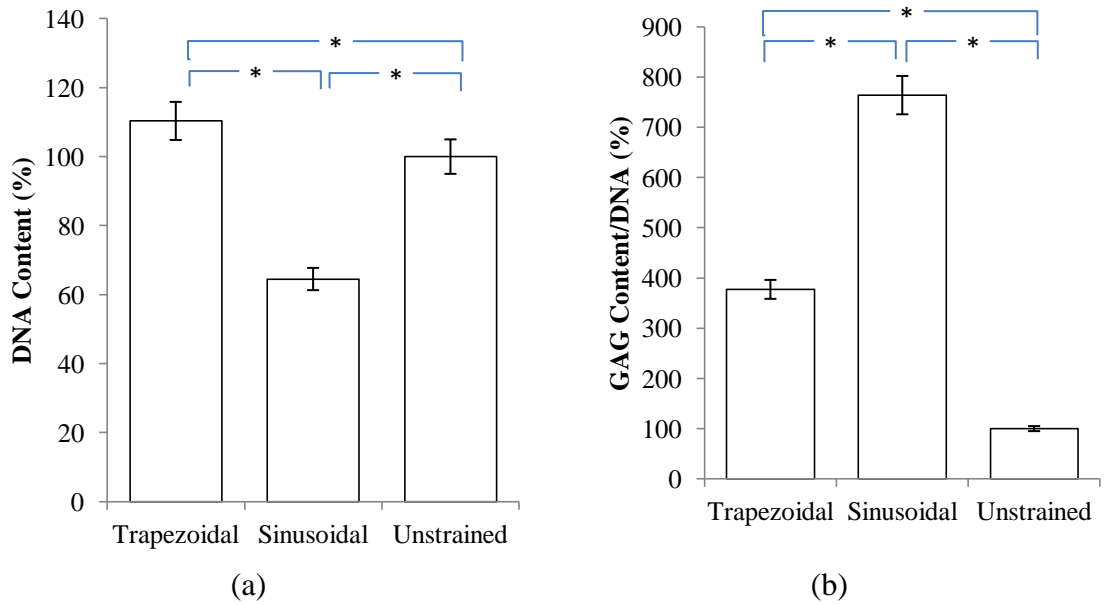

Figure 6.1 (a) Cell proliferation and (b) proteoglycan synthesis by chondrocytes seeded in agarose scaffold upon being loaded to trapezoidal or sinusoidal biaxial strain at magnitude of 10% direct and 1% shear compressive strain. Error bars represent means and SEM of 24 replicates, normalised to the control unstrained samples (100%). (*) showing highly significant values across the loading factor ($p < 0.05$).

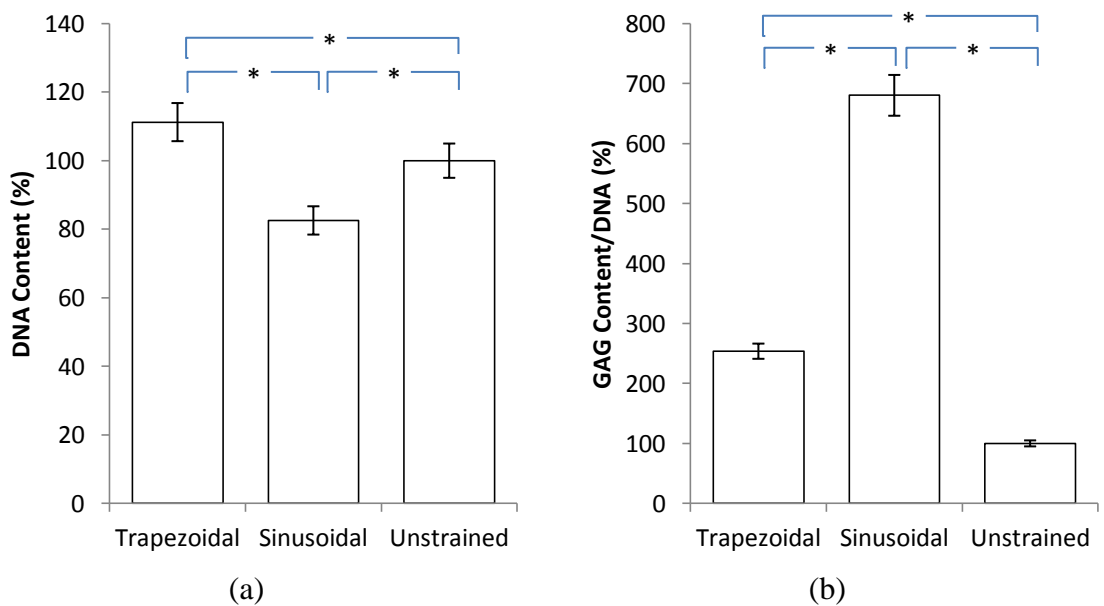

Figure 6.2 Upon free swelling pre-culture for 24 hours, the chondrocyte-agarose constructs were loaded in a biaxial manner. At the end of the experiment, DNA content (a) and proteoglycans synthesis (b) were quantified. The values are depicted as means and standard error. The values were normalised to unstrained samples as the control group. Two-way ANOVA test has shown that all data were significant to among those samples loaded under either trapezoidal, sinusoidal or even unstrained. (*) $p < 0.05$.

6.4. Discussion

Previous studies have shown that low amplitude dynamic compression induced stimulation of GAG synthesis in cartilage explants (Farshid Guilak, Meyer, Ratcliffe, & Mow, 1994; M. Jin et al., 2001; Wolf et al., 2007; M. Wong, Siegrist, & Cao, 1999) and in isolated chondrocytes cultured in three dimensional structures (M. Buschmann et al., 1995; Chowdury et al., 2003; Davisson et al., 2002; D. Lee et al., 2000; Shelton et al., 2003; Villanueva et al., 2009). Physiologically, articular cartilage in the load bearing joints experiences complex mechanical loading consisting of compressive, shearing and tensile forces in combination (Mankin et al., 1994). Studies on the effect of fluid-flow induced shear on monolayer cultured chondrocytes have shown up-regulation of nitric oxide (M. S. Lee et al., 2002). Exhibition of NO was reported to inhibit PG synthesis and cell proliferation in chondrocytes. Thus, this chapter which analyses the effect of direct compressive and shear loading on chondrocyte metabolic response, without incorporating any fluid shear is essential.

As described extensively in Section 8.2, some of the possible mechanisms involved in the transduction of dynamic compression are altered fluid pressure, enhanced fluid flow, and induced streaming potential, cell-matrix interactions, and growth factor release.

This particular chapter has shown that integration of direct shear strain to the mechanical loading regime causes a 7-fold increase GAG content in chondrocyte-agarose constructs compared to control samples. This result is parallel to another study which found increment in both collagen and PG concentration after 2% intermittent shear stimulation at 1 Hz for 400 cycles every second day, with 5% off-set compression

(Waldman et al., 2003). This increment in GAG content is more obvious in the constructs than in the medium. This stimulatory effect can be seen from both loading waveforms; sinusoidal and trapezoidal.

An inhibitory effect of sinusoidal dynamic biaxial load on chondrocytes is explained by the same reason as outlined in Section 7.4.

As outlined in Section 6.3.2, integration of 24 hours pre-culture of chondrocyte-agarose constructs before 48 hours sinusoidal mechanical load exposure at a frequency of 1 Hz, exhibits three-fold GAG production compared to the trapezoidal loaded chondrocyte-agarose constructs. Waldman et al. incorporates four weeks free-swelling pre-culture to the chondrocyte seeded constructs (2003). Sinusoidal dynamic mechanical load assimilates normal activity of human joints (i.e. walking).

In summary, chondrocytes seeded in 3D scaffolds and subjected to bi-axial loading incorporating superimposed compressive and shear strain responds with significant level of matrix synthesis. In agreement with previous studies, this chapter also shows that pre-culture of chondrocytes is an important pre-requisite for effective 3D culture, specifically in terms of cell proliferation.

Chapter 7. Discussion

7.1. Introduction

This chapter integrates all work described in the previous chapters of the thesis. It first illustrates the influence of biaxial mechanical load compared to the more widely investigated uniaxial mechanical loading of chondrocytes. Then, the benefit of pre-culture will be explained and discussed in detail.

Further sections draw on the general data analysis based on these results and these data will be discussed extensively. At the end of the chapter, an analysis of the experimental system utilized in this thesis is outlined as cell model, relevance of mechanical regimes, DNA and GAG quantification protocols.

7.2. Is biaxial loading beneficial to the metabolic response of chondrocytes?

Physiological loading patterns produced by gait and walking activities comprise a combination of loading forms, varying in terms approximately equivalent to frequency, force, waveform and duration, and including a variable mix of static, compressive, and shear loading components (Jennifer et al., 2003). The present study makes use of the well-established chondrocyte-seeded-agarose model and a bioreactor capable of highly flexible combinations of compressive and shear loading over a sustained period.

7.2.1. Comparing DNA Content and Proteoglycan Synthesis between Uniaxial and Biaxial Loading without 24 Hours Pre-Culture.

Data from sections 5.3.1 and 6.3.1 show the response of chondrocytes to uniaxial and biaxial loading. These values obtained from 48 samples are tabulated in Figure 7.1, given as a percentage difference to respective control unstrained samples. In both cases, direct with/without shear strains were applied to chondrocyte-agarose constructs immediately after being seeded.

Figure 7.1(a) shows that uniaxial loading with a trapezoidal waveform increased DNA content by 17% over the unstrained samples, compared to biaxial trapezoidal loading that increased DNA content by only 13% ($p>0.05$). No significant difference in value between the unstrained control specimens from these two experiments was observed ($p>0.05$).

An interesting effect of biaxial loading is that the sGAG incorporation of samples loaded under trapezoidal loading is higher compared to the control samples, even though the respective DNA levels are lower than those loaded uniaxially. In addition, sGAG incorporation measured from medium loaded under uniaxial to biaxial regimes is approximately 1:1. Table 7.1 summarises the level of PG detected in medium and in digested constructs upon being loaded. PG measurements in constructs (when loaded in a biaxial manner) were twice as high as of uniaxially loaded samples. This might suggest that biaxial loading increases sGAG incorporation within the constructs.

As summarised in Table 7.2, biaxial loading is more effective with respect to total GAG synthesis. However, biaxial loading has been statistically shown to be insignificant as to its effect on the DNA content of loaded constructs. As depicted in

Table 7.3, chondrocytes responded most to the trapezoidal waveform in terms of increasing DNA content, while sinusoidal waveform proved the least effective. Yet, sinusoidal waveforms give the highest PG production, in both uniaxial and biaxial loading systems.

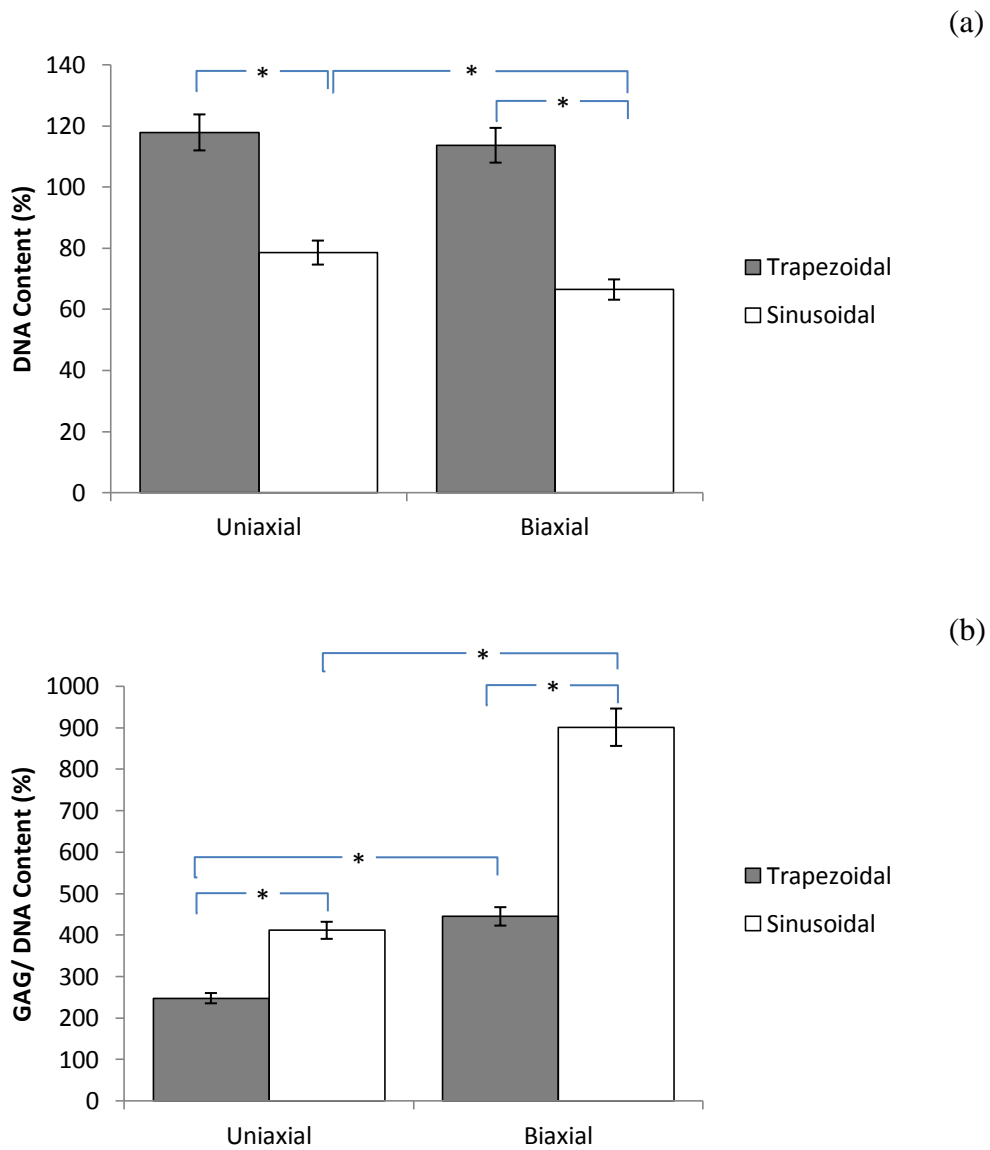

Figure 7.1 The effect of uniaxial and biaxial loading on chondrocytes when cultured under compressive strain on cell proliferation and proteoglycan production. These data are normalised to the respective control unstrained samples (100%) to eliminate other uncontrollable variables. Each data is reported as mean and standard error (n=24) with (*)p<0.05.

A two-way ANOVA shows an interaction value of $p < 0.05$ for PG synthesis, exhibiting cross effect between the uniaxial/ biaxial and loading waveform, but no cross effect has been detected for DNA content. The main effect of loading waveforms on the level of DNA, regardless of uniaxial or biaxial loading, can be seen graphically as illustrated in Figure 7.2(a) which shows two parallel line graphs suggesting no interaction between the two factors ($p > 0.05$), while Figure 7.2(b) suggesting that the two lines will meet ($p < 0.05$). This suggests that both sinusoidal and biaxial load enhanced production of GAGs.

Table 7.1 Proteoglycan levels detected in medium and in digested constructs upon being exposed to compressive and/nor shear strain.

<i>Uniaxial Loading : Biaxial Loading</i>	
GAG_{Medium}	1:1
$GAG_{Constructs}$	2:1

Table 7.2 Mean of DNA content and proteoglycan synthesis, as a total of trapezoidal, uniaxial and unstrained uniaxial or biaxial loading. Values shown are means and SEM of 24 replicates in four separate experiments. Otherwise stated by ^{ns} showing insignificant comparison, values are significant with $p < 0.05$.

	$GAG_{Medium}/$ $DNA (\mu g/\mu g)$	$GAG_{Construct}/$ $DNA (\mu g/\mu g)$	$GAG_{Total}/$ $DNA (\mu g/\mu g)$	$DNA Content$ (μg)
Uniaxial Loading	1.003 ± 0.665	0.642 ± 0.131	1.286 ± 0.600	3.063 ± 1.009^{ns}
Biaxial Loading	0.644 ± 0.197	1.537 ± 1.140	2.540 ± 3.073	2.955 ± 1.113

Table 7.3 Loading regime that shows stimulation effect to increase DNA content and proteoglycan synthesis in both uniaxial and biaxial cases. Data is based on values which represent means \pm SEM. (**)
 $p < 0.05$

DNA Content	Trapezoidal > Unstrained > Sinusoidal**
Proteoglycan Synthesis	Sinusoidal > Trapezoidal > Unstrained**

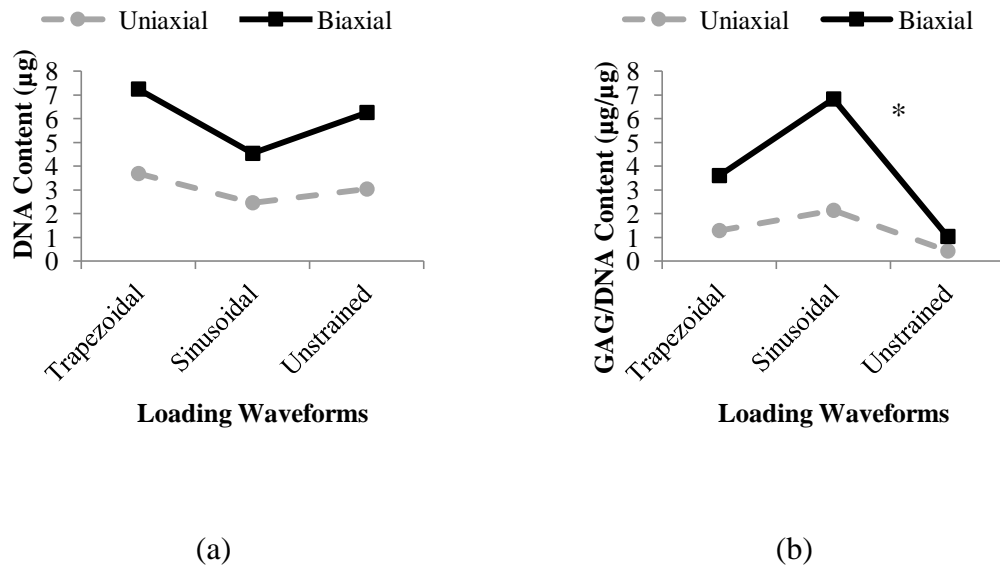

Figure 7.2 Interaction effect found to be significant in proteoglycans production (b), but not in DNA content (a). This cross effect have shown that two factors (uniaxial/biaxial) and loading waveforms contribute to higher production of proteoglycans, (*) $p < 0.05$.

7.2.2. Comparing DNA Level and GAG Synthesis between Uniaxial and Biaxial Loading Upon Pre-Culturing for 24 Hours

The mean percentage of cellular DNA and GAG levels upon exposure to 10% direct with/ without 1% shear compressive strain(s) is tabulated in Figure 7.3. A total of 24 samples for each condition were used to tabulate these data, samples being subjected to either uniaxial or biaxial loading protocols separately in weekly experiments. Potential batch variations and environmental condition differences were addressed by normalising each value to its respective control unstrained condition. In addition, the values from unstrained groups done by biaxial and uniaxial loading were compared and found not to be significantly different. This comparison is essential to provide confirmation that all experiments were set up in controlled environments and that other factors were constant, besides mechanical loading regimes (waveform/ multi- or uni-directional). The samples were also subjected to a free-swelling pre-culturing period for 24 hours prior to exposure to uniaxial loading, biaxial loading, or being held unstrained.

Thus, all control groups from both set of experiments (uniaxial and biaxial) were cultured without strain for a total of 72 hours.

Upon 24 hours pre-culture, chondrocytes seeded within agarose constructs were subjected to 10% direct compression for uniaxial loading, while half of the samples were subjected to 10% direct and 1% shear compression for biaxial loading. Table 7.4 indicates that biaxial loading gives stimulatory effects to the production of glycosaminoglycan, both in medium and in digested constructs. Using DNA as the baseline, GAG_{Total}/DNA in constructs loaded in biaxial manner was found to be 55% higher than the uniaxial loaded constructs ($p < 0.05$). However, biaxial loading gives the reverse effect on the DNA content in digested constructs. The DNA level in uniaxial loaded constructs was slightly higher in comparison to DNA level within chondrocytes that were subjected to biaxial loading ($p < 0.05$).

Table 7.5 summarises the stimulatory effects of loading waveforms on DNA content and proteoglycan synthesis in both uniaxial and biaxial cases, in terms of the degree of response. The values measured for DNA content and PG synthesis are statistically distinctive ($p < 0.05$).

In terms of loading, trapezoidal and sinusoidal waveforms for both uniaxial and biaxial phenomena give different stimulatory effects onto chondrocytes within agarose constructs. It was found that sinusoidal loading, regardless of uniaxial or biaxial loading affects chondrocytes such in a way that chondrocytes exhibit GAG synthesis. On the other hand, sinusoidal loading has the lowest affirmative effect on DNA content, while trapezoidal loading stimulates the highest DNA content among all specimens.

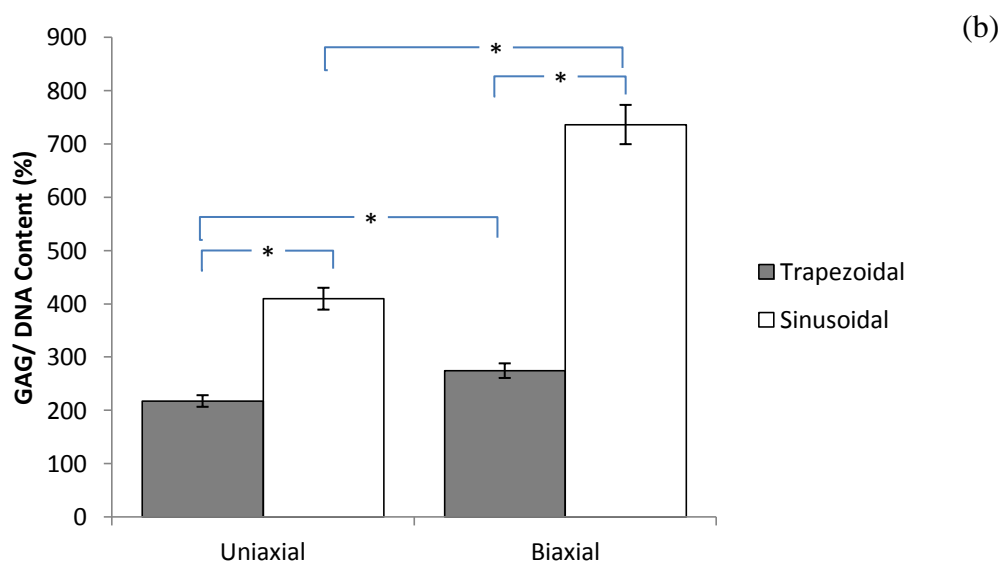
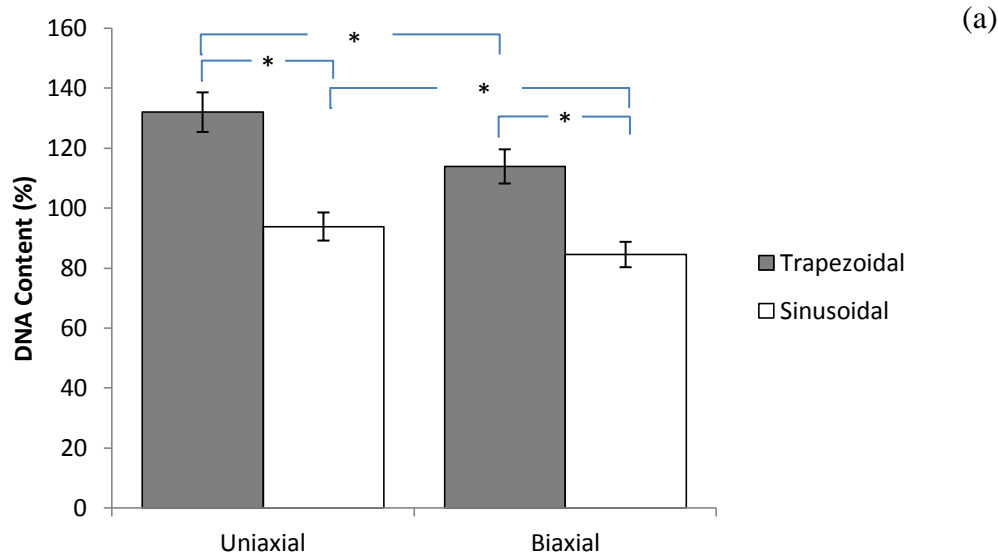

Figure 7.3 The effect of dynamic compression either by uniaxial or biaxial loading at different waveform on the DNA content (a) and proteoglycan synthesis (b), shown as percentage, normalised to the values of unstrained control group (100%- not shown in graph). The specimens were pre-cultured under free-swelling for 24 hours prior to being subjected to loading. Total number of samples involved was 24 samples for each condition and tests were replicated in separate weekly experiment. (*) $p < 0.05$.

Two-way ANOVA tests have shown an interaction effect for both DNA content and proteoglycan production. Figure 7.4 shows line graphs of (a) DNA content and (b) GAG measurement from uniaxially or biaxially strained chondrocytes. Line graph (a) will eventually cross each other someplace off the graph, if the lines were to be

extended, while line graph (b) shows two lines meet near the unstrained values, indicating that, upon pre-culturing, both loading waveform and uni/multi-directional loading gives interaction effects to DNA and GAG content.

Table 7.4 Mean value of all 24 samples from biaxial and uniaxial loading. The samples were put to free-swelling for the first 24 hours before subjected to loading. All values are normalised to the control unstrained group and a two-way ANOVA has given p value of less than 0.05(**), suggesting significant values for all measurements at all conditions.

	GAG_{Medium}/DNA ($\mu g/\mu g$)	$GAG_{Construct}/DNA$ ($\mu g/\mu g$)	GAG_{Total}/DNA ($\mu g/\mu g$)	DNA Content (μg)
Uniaxial Loading	0.615 ± 0.161	1.057 ± 0.489	1.672 ± 0.951	$4.031 \pm 0.778^{**}$
Biaxial Loading	$1.145 \pm 0.846^{**}$	$1.457 \pm 0.962^{**}$	$2.602 \pm 3.591^{**}$	3.749 ± 0.293

Table 7.5 Loading regime that shows stimulation effect to increase DNA content and proteoglycan synthesis in both uniaxial and biaxial cases. (**) $p < 0.05$.

DNA Content	Trapezoidal > Unstrained > Sinusoidal**
Proteoglycan Synthesis	Sinusoidal > Trapezoidal > Unstrained**

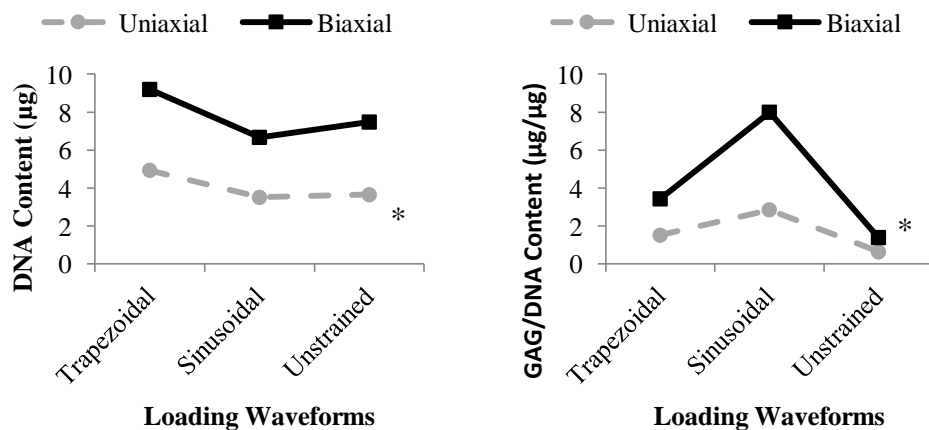

(a)

(b)

Figure 7.4 Interaction effect found to be significant in DNA content (a) and proteoglycans production (b). This cross effect have shown that two factors (uniaxial/biaxial) and loading waveforms contribute to higher production of proteoglycans, (*) $p < 0.05$.

In the present study, investigation into the effect of uniaxial and biaxial loading on chondrocytes has shown that biaxial loading has an advantage over uniaxial loading in terms of synthesis of ECM. Our findings are in parallel to other studies that contemplated that shear strains at a low range (1-3% strains) stimulated matrix synthesis in cartilage explants (Frank et al., 2000; M. Jin et al., 2001). An application of simple shear strains was observed to induce local pressure gradients and relative fluid flow at the thin peripheral edge regions (M. Jin et al., 2001). Compression on the surface of cartilage has shown compaction of the pericellular, territorial and interterritorial matrix around the cells (M. Buschmann et al., 1995; F. Guilak et al., 1995). Load on cartilage has also shown changes to the cell and nucleus surface area (M. Buschmann et al., 1995; F. Guilak et al., 1995; J. Urban, 1994). The multiple regulatory pathways initiated by the direct and shear compression are explained in detail in Section 8.2.

On the other hand, a study on the effect of shear deformation on full-thickness explant cartilage has found that maximal shear strain was experienced by the chondrocytes at the articulating surface. The effect decreased monotonously with depth (B. L. Wong et al., 2008).

7.3. Is Pre-Culture Advantageous To The Chondrocyte Response?

This sub-chapter will assess the differential effect of a period of free-swelling recovery upon subsequent mechanotransduction by chondrocytes. Buschmann et al. (1995) suggests this pre-culture period to be a beneficial step.

7.3.1. Pre-Culturing Affects DNA Content and total GAG Production by Chondrocytes Loaded in Uniaxial Manner

Data from sections 5.3.1 and 5.3.2 permit comparison to see the effect of 24 hours pre-culturing on chondrocytes. Table 7.6 summarises mean values of DNA and GAGs measurements for both non pre-cultured (NPC) and pre-cultured (PC) samples for all loading conditions. PC specimens have been shown to yield a highly significant increase in both GAG and DNA content, compared to constructs exposed to loading immediately after seeding ($p < 0.05$).

Data from a total of 144 samples are combined in Figure 7.5, categorised as DNA content (a) and PGs production (b). Pre-culture demonstrates a positive effect on DNA levels in chondrocytes within the agarose scaffold. Even the PC unstrained samples have a 20% higher DNA content ($p < 0.05$) than the NPC ones. Note PC samples were cultured under free-swelling for a total of 72 hours, whereas NPC samples were cultured for only 48 hours.

Table 7.6 Mean values of DNA content, GAGs measured in medium and in constructs of non pre-cultured (NPC) and pre cultured (PC) specimens for all loading conditions. There were about 24 samples for each case. DNA levels were used as the baseline for proteoglycan synthesis measurement. Values shown as mean \pm SEM. Unless stated, ** shows p value of less than 0.05 between NPC and PC samples.

	$GAG_{Medium}/$ $DNA (\mu g/\mu g)$	$GAG_{Construct}/DNA$ $(\mu g/\mu g)$	GAG_{Total}/DNA $(\mu g/\mu g)$	$DNA Content$ (μg)
Non Pre-Cultured (NPC)	1.003 ± 0.665	0.642 ± 0.131	1.286 ± 0.600	3.063 ± 1.009
Pre-Cultured (PC)	0.615 ± 0.161^{ns}	$1.057 \pm 0.489^{**}$	$1.672 \pm 0.951^{**}$	$4.031 \pm 0.778^{**}$

Both PC and NPC samples show values of DNA content lower than unstrained samples, suggesting an inhibitory effect of sinusoidal waveforms to DNA levels. Albeit, DNA content in PC samples exposed to sinusoidal uniaxial loading was measured and found to be 40% higher than in the NPC samples. There is an increment of about 40% of DNA content in PC over NPC samples when loaded with a trapezoidal waveform.

The average values for total GAG synthesis of PC and NPC samples, (as shown in Table 7.6) are $1.67 \mu g/\mu g$ and $1.29 \mu g/\mu g$ respectively, regardless of the type of loading. These mean values indicate an advantage to 24 hour pre-culture of chondrocytes, prior being subjected to loading. Control group unstrained PC samples that were cultured under free-swelling for a total of 72 hours produced about 20% more GAGs than the NPC samples.

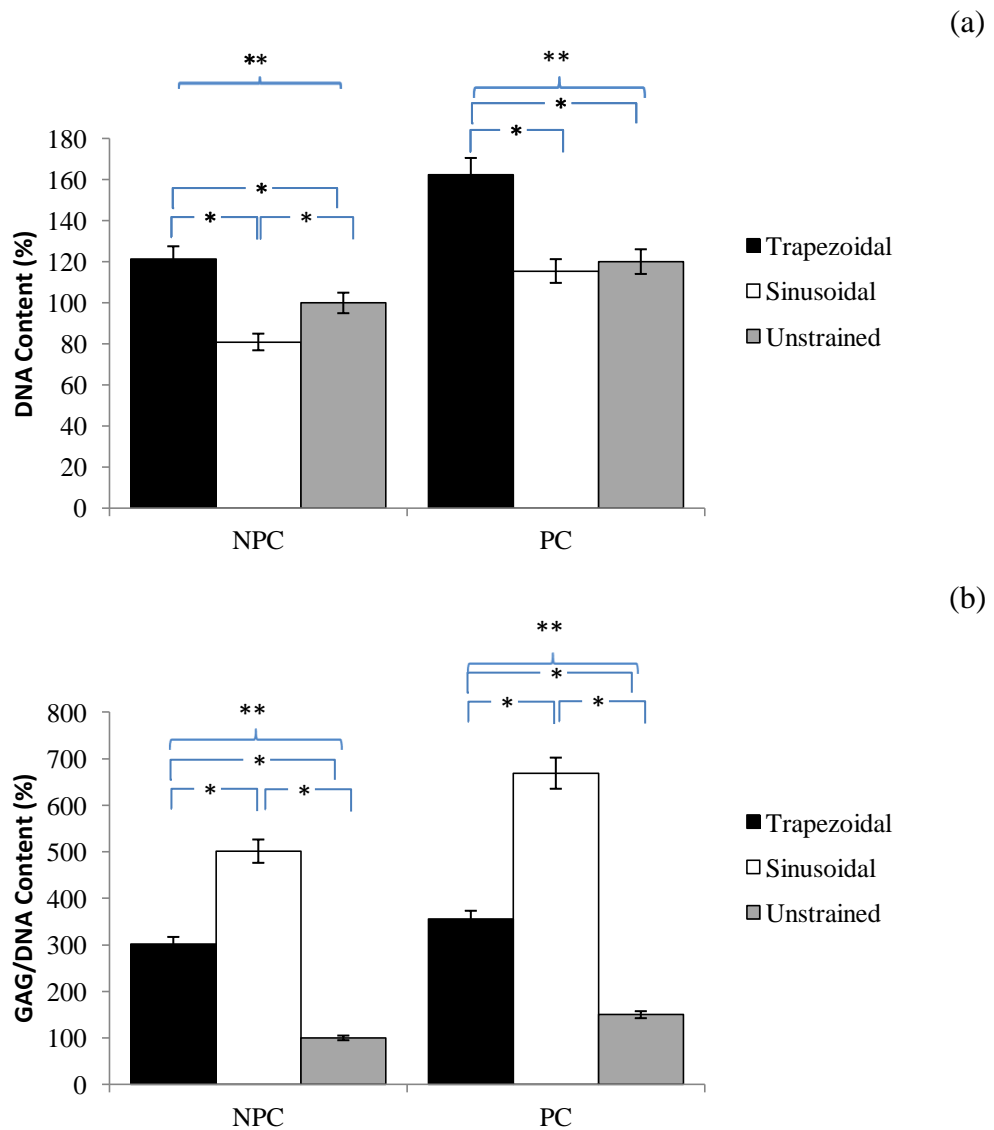
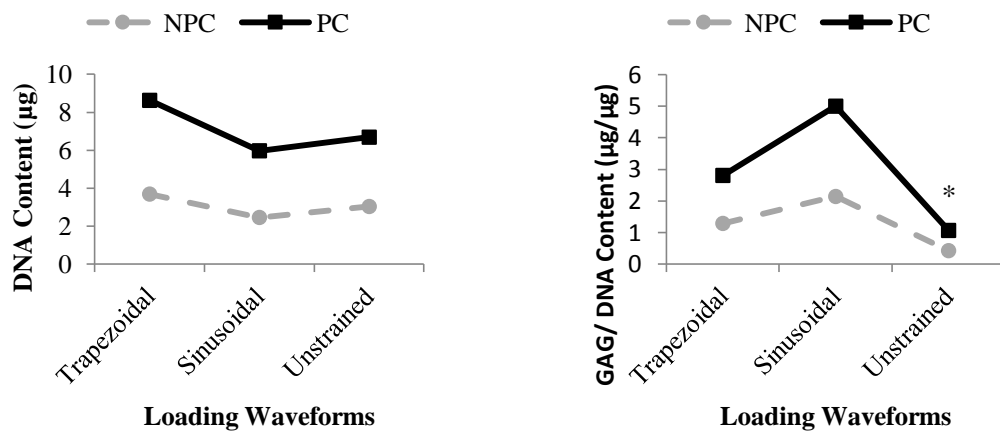

Figure 7.5 Trapezoidal and sinusoidal uniaxial strained constructs measured (a) DNA content normalised to control NPC unstrained specimens (100%) and (b) proteoglycans synthesis, also normalised to control NPC unstrained samples (100%). In both DNA and GAG level, pre-cultured (PC) samples seem to have advantages over the non-pre-cultured (NPC) ones. 24 hours pre-culturing significantly increase DNA content and proteoglycans production in all three cases (trapezoidal, sinusoidal and unstrained). (*) $p < 0.05$, while (**) also indicates $p < 0.05$ for all loading conditions.

An interaction effect between integrating pre-culturing and loading waveforms can be seen in terms of GAG production, but not DNA content. The main effect can be seen in Figure 7.6(a) and suggests that the DNA content measured within chondrocytes seeded in agarose constructs is significantly affected by pre-culturing, while Figure 7.6(b) shows an interaction effect where GAG level depends on both pre-culturing and loading waveforms factors.



(a)

(b)

Figure 7.6 Line graphs showing interaction effect for DNA content (a) and GAG production (b). No interaction can be seen for DNA content between NPC and PC samples ($p > 0.05$). The graph shows that there are cross effect for GAG production between non pre-cultured (NPC) and pre-cultured (PC) specimens, suggesting that the results of GAG production depends on pre-culturing factor and loading factor. (*) signifies $p < 0.05$.

7.3.2. Pre-culturing Affects DNA Content Measured within Chondrocytes Loaded in Biaxial Manner.

Table 7.7 summarises mean values of data from a total of 144 samples, half of which were left under free swelling for 24 hours prior to exposure to biaxial loading, the other half being subjected to load immediately after the chondrocytes were seeded in the agarose scaffold. Pre-cultured (PC) samples have an advantage over non pre-cultured (NPC) in terms of stimulating higher cellularity, but no obvious difference is observed in GAG production.

Taking all three types of biaxial loading (sinusoidal/ trapezoidal/ unstrained) into consideration, data from each type of loading shows pre-cultured (PC) is beneficial for all loading waveforms. Figure 7.8(a) shows a 20% increase of DNA content, which can be seen from the PC samples against NPC samples in trapezoidal and unstrained

conditions. Moreover, DNA content of PC samples is increased by 30% when the constructs are subjected to sinusoidal loading, compared to the NPC samples.

A two-way ANOVA analysis confirms that there is no significant difference in GAG production between PC and NPC specimens. Nevertheless, Figure 7.8(b) demonstrates a trend in the effect of each waveform type of biaxial loading on GAG production. In both PC and NPC cases, as illustrated in Figure 7.7, sinusoidal loading has the most significant effect on chondrocytes in terms of PG synthesis.

The interaction effect between NPC/PC and loading waveforms is depicted in Figure 7.9. DNA content (refer Figure 7.9a) is mainly affected by pre-culturing ($p > 0.05$), while an interaction effect can be seen in the GAG production (refer Figure 7.9b), suggesting interaction between pre-culture and loading waveforms; simultaneously bringing enhancement of synthesis of new molecular to produce new ECM, marked by a higher level of GAG ($p < 0.05$).

Table 7.7 Mean values for GAG in medium, constructs and DNA content in all samples (n=72) for non pre-cultured (NPC) group and pre-cultured (PC) group. It is shown that PC has a significant effect on GAG_{Medium}/DNA and DNA content (**) $p < 0.05$.

	GAG_{Medium}/DNA ($\mu g/\mu g$)	$GAG_{Construct}/DNA$ ($\mu g/\mu g$)	GAG_{Total}/DNA ($\mu g/\mu g$)	DNA Content (μg)
Non Pre-Cultured (NPC)	0.644 ± 0.197	1.537 ± 1.140	2.540 ± 3.073	2.955 ± 1.113
Pre-Cultured (PC)	$1.145 \pm 0.846^{**}$	1.457 ± 0.962^{ns}	2.602 ± 3.591^{ns}	$3.749 \pm 0.293^{**}$



Figure 7.7 A trend of biaxial loading waveforms from the least to the most significant in terms of producing stimulation effect on chondrocytes to proteoglycans synthesis.

(a)

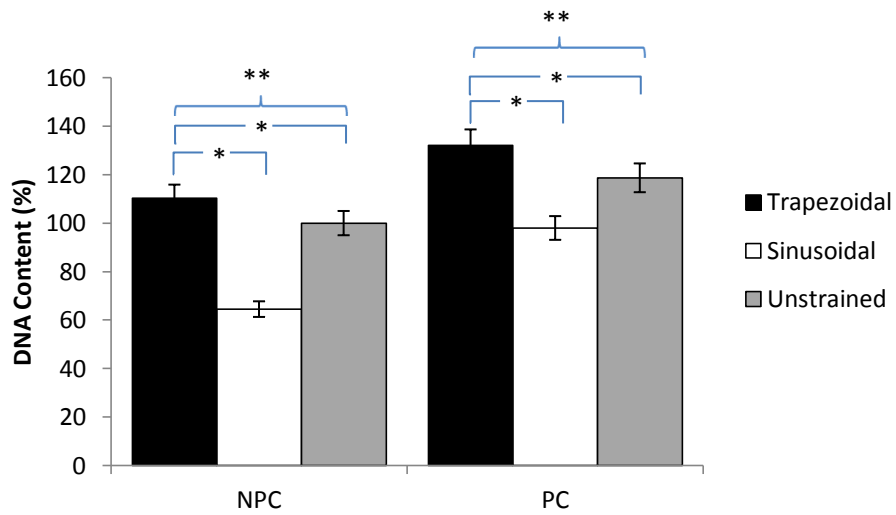

(b)

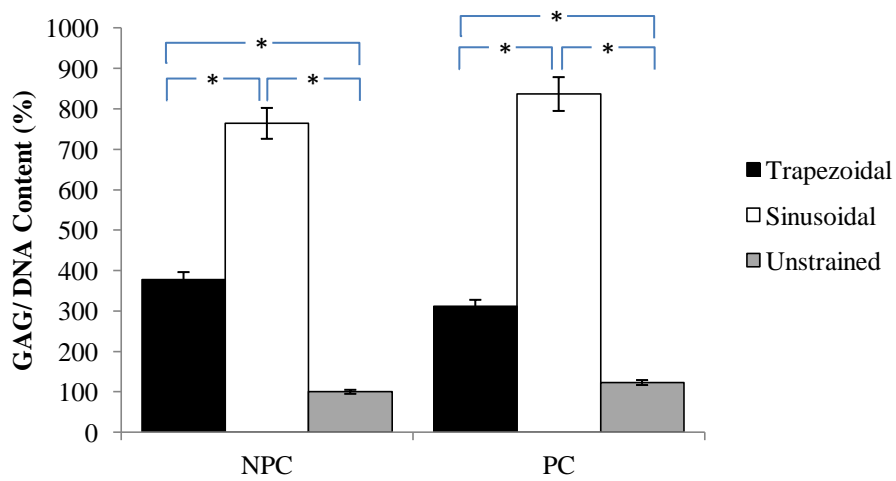
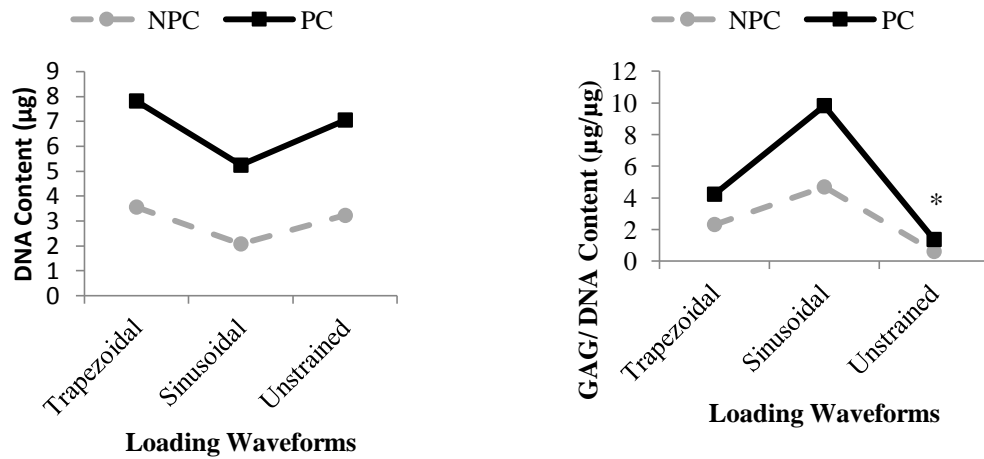

Figure 7.8 Data were collected to see the effect of (a) DNA content, normalised to the unstrained samples as the control group (100%) and (b) proteoglycan production by chondrocytes seeded in agarose loaded in biaxial manner immediately after cell seeding or upon 24 hours pre-culture under free-swelling condition. The data were taken from a total of 72 samples for each pre-cultured (PC) and non pre-cultured (NPC) conditions. (*) $p < 0.05$, while (**) also indicates $p < 0.05$ for PC samples versus NPC samples in all loading conditions.



(a) (b)
 Figure 7.9 Interaction effect of non pre-cultured and pre-cultured specimens in terms of a) DNA content and b) chondroitin sulphate incorporation using DNA content as the baseline. Graphs show that cross effect can be seen from the level of proteoglycan synthesis (* signifies $p < 0.05$), but no cross effect for DNA content ($p > 0.05$).

Subsequently, cell proliferation and matrix production was found to be significantly higher in pre-cultured chondrocyte-agarose constructs. The samples were left free-swelling for 24 hours upon seeding. The newly-formed pericellular matrix around chondrocytes within the agarose has a higher elastic modulus than agarose/chondrocyte constructs (Knight et al., 1998). Buschmann (1995) shows the readiness of cells after one day, by measuring hyaluronan and integrin. Within the scaffold, the cells proliferate and synthesize matrix molecules, which are subsequently deposited within the construct and/or released into the growth medium (M. Buschmann et al., 1995). The release of GAG to the medium may be due to the aggregability, catabolism of IG matrix or ‘washing out’ of unincorporated GAG due to convective transport (Hunter et al., 2004).

As suggested by Hunter et al. (2004), the mechanical signals transmitted to cells may vary substantially between different scaffold environments. While chondrocytes in native tissue bound to the ECM via cell adhesion, which can transfer matrix strains to mechanosensitive ion channels directly to the cytoskeleton; in agarose, cells adhere to

polysaccharide molecules. That is why pre-culture is also essential when polysaccharide matrices such as agarose or alginate is used. With pre-culturing, cells are able to bind to the new pericellular matrix as it is deposited, thus providing biomechanical interaction between the pericellular environment and the chondrocytes (Farshid Guilak & Mow, 2000; Hunter et al., 2004). Besides providing structural support, mechanical strength and attachment sites, ECM also envelopes signalling molecules that modulate cellular functions such as proliferation, migration and differentiation (Wang & Thampatty, 2006).

7.4. General Data Analysis

In the final analysis, data from samples either used instantaneously or following 24 hours pre-culture, then subjected to uniaxial or biaxial loading (trapezoidal/sinusoidal), were gathered to assess their effect on DNA and GAG production (refer Figure 7.10 and Figure 7.11).

DNA content was extracted from papain-digested agarose constructs containing chondrocytes. The DNA level was quantified as explained in Section 3.4.2. DNA is contained within the chondrocyte nucleus, and ECM is broken down by papain activated enzymes.

Overall, trapezoidal mechanical load has the highest proliferation stimulatory effect for both uniaxial and biaxial loading types, regardless of being pre-cultured or not. Among all samples that were subjected to trapezoidal uniaxial or trapezoidal biaxial loading, the pre-cultured group gives a higher reading for DNA level.

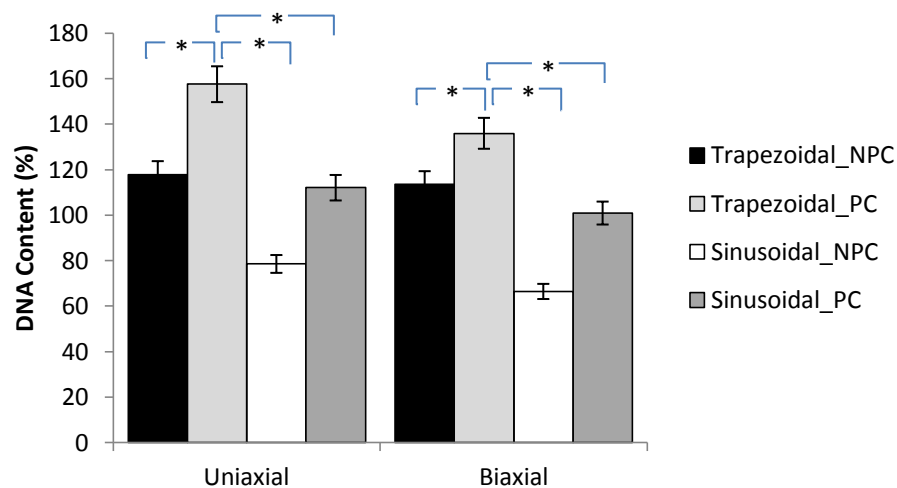

Figure 7.10 DNA level measured from digested constructs that were either loaded trapezoidal/sinusoidal or were left unstrained as the control group (100%- not shown in graph). The loading regime was set to 10% direct and/nor 1% shear compressive strains. Half of the agarose constructs were directly subjected to load upon seeding with chondrocytes, while the other half were pre-cultured for 24 hours prior to be subjected to load. Data were tabulated from 24 samples for each condition and each data was normalised to control unstrained groups. (*) $p < 0.05$. As a sum, uniaxial gives higher effect on DNA content regardless of loading waveforms ($p < 0.05$).

For the case of DNA level, it is shown in the graph above that uniaxial loading has an advantage over the biaxial loading ($p < 0.05$).

As described in Section 2.1.3, GAG is a type of polysaccharide that can be found in the proteoglycans that make up the protein molecules of cartilage ECM. The GAG level, as depicted in Figure 7.11, is measured to assess the level of new molecular protein synthesis with effect to various independent variables.

In all conditions, for biaxial and uniaxial loads, pre-cultured samples have shown to be significant to contribute to higher level of GAGs, with the exception of PC samples loaded in biaxial trapezoidal manner. Chondrocytes seeded in agarose scaffold favour biaxial loading that leads to increment of GAG synthesis, with regard to both trapezoidal and sinusoidal loading. Primarily, 1 Hz-sinusoidal loading regime is strikingly effective in terms of increasing GAG synthesis.

Predominantly, chondrocytes were more metabolically active if pre-cultured for 24 hours upon seeding before being subjected to any load, and under biaxial loading for increasing both DNA and GAG levels. Nevertheless, a trapezoidal waveform has an advantage over sinusoidal in terms of a higher DNA content, while chondrocytes seem to respond better to sinusoidal loading when it comes to proteoglycan synthesis (refer to Table 7.8).

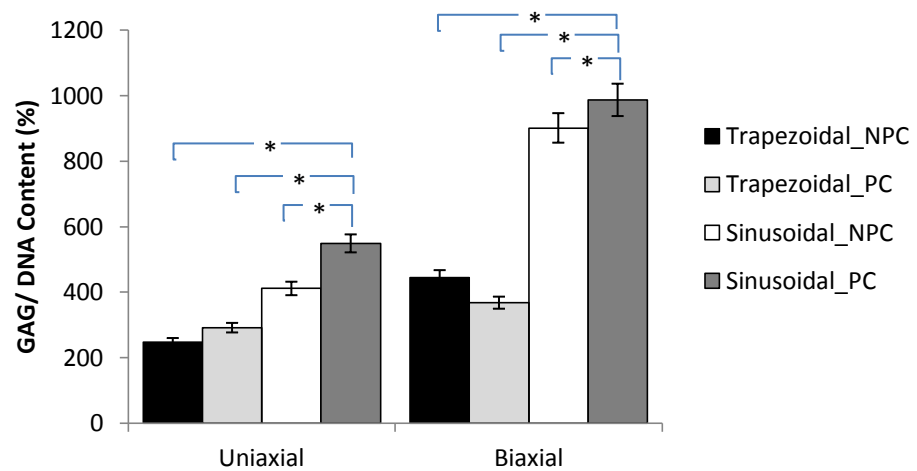

Figure 7.11 GAG content is assessed from all samples loaded either uniaxial or biaxial (trapezoidal/sinusoidal) as well as the control unstrained groups (100% - not shown in graph). Both non pre-cultured (NPC) and pre-cultured (PC) samples are also taken into account. The data comes from the same number of replicates for each case, $n=24$. Data from each case were shown to be highly significant for (*) where $p < 0.05$. In a sum, biaxial gives stimulatory effect to GAG production ($p < 0.05$).

Table 7.8 Analysis of combination of all factors, non pre-cultured (NPC)/ pre-cultured (PC) and loading regimes, using a three-factor ANOVA using SPSS. Equal replications of 24 samples for all conditions were used to tabulate these data. (**) p<0.05.

Effects	Comparisons	Results	
		DNA Level	Total GAG/ DNA
Overall	NPC vs. PC	PC mean > NPC mean** (3.89>3.01)	PC mean > NPC mean** (2.14>1.91)
	UNIAXIAL vs. BIAXIAL	BIAX mean < UNI mean** (3.35<3.55)	BIAX mean > UNI mean** (2.57>1.48)
	LOAD	TRAP>UNS >SIN ** (4.11>3.44>2.80)	SIN>TRAP>UNS ** (3.71>1.76>0.61)

12 hours trapezoidal loading nearly imitates static compression when continuous compression of constant amplitude is given throughout the whole period of 12 hours. This type of compression reduces the porosity of the agarose scaffold, limiting the transport and mobility of molecules and nutrients. Permanent compression increases negative ions and increases pH, thus decreasing water attraction, reducing cell-ECM volume (M. Buschmann et al., 1995).

Two 12-hour blocks were shown by Chowdhury et al. (2003) to be better than one 12-hour block or one 24-hour block, suggesting 43200 cycles (12 hours) is already beyond the threshold for the cells. It was also observed that the highest DNA content was found in 1.5 hour intermittently compressed constructs and further compression caused inhibition of cellularity. Hunter et al. (2004) suggested that stimulation interspersed with periods of rest might enhance tissue formation. This resting period is

essential to give way to the cells to restore its sensitivity. Continued compression might have caused mechanosensory saturation that would cause decreasing sensitivity of cells to mechanical stimuli with further loading (Hunter et al., 2004; Robling, Hinant, Burr, & Turner, 2002).

The effect of compression of a cartilage explant has also shown that after being left stress-relaxed for an hour, the explant samples were observed to depressurize and eventually approach a steady-state condition. However, the cartilage explant continuously experiences shear stress effects, which are believed to result from interstitial fluid pressures and kinetic friction (B. L. Wong et al., 2008).

Joint immobilization or disuse of joints leads to modification of the cartilage matrix. In the worst cases the cartilage eventually loses its mechanical functionality. When the cell-seeded constructs are exposed to static compression, the fluid will be drawn out of the matrices and charge instability caused by the fixed negative charge of the proteoglycan will entice the ions from the medium. This phenomenon will affect the pH of the tissue. The pH alteration will trigger transforming growth factor (TGF- β) that will lead to the apoptosis of chondrocytes and production of bone morphogenetic protein (BMP) that will initiate the calcification of cartilage. This will indirectly result in joint immobilization. The cartilage depends on the biphasic properties of its ECM to withstand the compression and prolonged static compression will force the collagen fibres to align parallel to the force vector. The modification to the physical structure of the ECM will reduce the matrix pore size and limit mass transport of nutrients to and wastes from cells. To conclude, static compression will depress the production of matrix synthesis that is essential for the survival of chondrocytes (McMahon et al., 2008).

Lee (2000) assessed the effect of dynamic loading on chondrocytes isolated from superficial and deep zones of cartilage. Unstrained specimens show higher DNA content for deep cells than superficial cells. Dynamic loading shows an increased DNA content in superficial cells but does not have any effect on deep cells. Dynamic loading increased PG by 50% in deep cells, with deep zones having greater overall activity, but limited ability to proliferate. This might suggest full-thickness cartilage is essential in load research as mentioned in Section 2.1.2 and Section 2.2.3; each zone has its own mechanical properties with varied collagen orientation and cell shape throughout the depth. The heterogeneity in composition and structure is responsible for the resistance of cartilage to different types of load.

Throughout this study, the load was delivered at a frequency of 1 Hz. Previous studies have found that 1 Hz is an optimal frequency, compared to 0.3 or 3 Hz (Shelton et al., 2003). It has been shown that increased frequency will affect the effective width of the peripheral ring negatively (D. Lee et al., 2000; Sah et al., 1989). Besides, Fan and Waldman (2010) suggested that the rate of acidification of the media accelerates with increasing frequency of loading. A change in medium pH is contributed by post-production of glucose metabolism anaerobically. Deep cells loaded dynamically at 0.3 Hz show a stimulatory effect to [³H]-thymidine incorporation compared to other frequency regimes (Shelton et al., 2003).

This study has also shown that 1 Hz-sinusoidal mechanical regime inhibits DNA synthesis in chondrocytes. Considering multiple phase of cell cycle, it might take a while for cells to complete one cell cycle. Freshly isolated chondrocytes are highly metabolically active until they have had time to deposit some of their own matrix

(Quinn, Schmid, Hunziker, & Grodzinsky, 2002). Subsequent studies by Waldman et al. (2007; 2003) have shown that intermittent multi-axial loading on chondrocytes caused a decline in total DNA content of stimulated samples. It is believed that this might be caused by either cell death or inhibition of the cell cycle. Stimulation of cell proliferation was found to be maximal for chondrocytes subjected to 1.5 hours of dynamic continuous compression. Further cycles of dynamic strain reduced the probability of the cell entering s-phase during the 48 hours period (Chowdury et al., 2003). An initial study into cell viability and cell cycle progression was seen to be inhibited by mechanical stimulation. However, once a proper ECM is built, the stimulation starts to show a positive effect. In a study by Huselstein (2006) the positive effect is only seen after 21 days.

Some of the possible mechanisms involved in the transduction of dynamic compression are; altered fluid pressure, enhanced fluid flow, induced streaming potentials, cell-matrix interactions and growth factor release. Besides cell and nucleus deformation, dynamic loading enhances convective transportation of mobile solute, especially on the transport of larger molecules such as ADP and growth factors; and fluid flow convecting mobile counterions past ionized charge groups on immobilized macromolecules generates streaming potentials (M. Buschmann et al., 1995).

7.5. Experimental System

7.5.1. Cell Model

Cell Source

The ultimate goal of research in tissue engineering is to enhance the quality of human lives by offering an option to recreate cells and tissues that are capable of restoring lost function. In this present study, a bovine cell source was preferred over a human cell source for various reasons. The bovine cell source was readily available and its size makes it yields large numbers of cells following isolation. Cell yield is essential as a head start in this study as otherwise the work would require an additional step of expansion in monolayer culture. It was reported that chondrocytes which underwent monolayer culture experienced dedifferentiation (Frohlich et al., 2007).

Cell Seeding Density

Initial high cell seeding and uniform cell distribution has been proved to increase the rate of cartilage matrix formation (Ivan Martin, Wendt, & Heberer, 2004). Mauck et al.(2003) seeded chondrocytes in agarose scaffold at concentrations of 10 million cells.ml⁻¹ and 60 million cells.ml⁻¹. It was found that there was more than twice the increase in mechanical properties of higher density seeded agarose constructs, and the GAG analysis has also been shown to be significantly higher than those construct under free-swelling.

There was another study that manipulates seeding density and distributions of chondrocytes in polyglycolic acid (PGA) scaffolds. Chondrocytes were seeded at 2.5, 5 or 10 million cells.ml⁻¹. Even though cell viability and GAG content per constructs have

shown to be excellent in the highest density chondrocytes, the spatial distribution of the cells was found to be more reflective when only intermediate concentration of chondrocytes were applied (Bueno et al., 2007).

Thus, it is suggested that a lower cell seeding density is preferential for constructs where mechanical stimulation is applied. There were only 8 million cells.ml⁻¹ and 10 million cells.ml⁻¹ chondrocytes seeded in agarose constructs prior to mechanical loading (Chowdury et al., 2003; B Pingguan-Murphy et al., 2005).

Scaffold

An ideal scaffold must be three-dimensional, highly porous with an interconnected pore network, be biocompatible and have a controlled degradation rate. The scaffold must be compatible while enveloping the cells and it must also not produce toxic post degradation particles (Yun & Moon, 2008).

The dimensions of the construct were (5x5x5) mm. This thickness is similar to the thickness of native cartilage, which ranges from 1 to 5 mm (Heywood, Sembi, Lee, & Bader, 2004).

Agarose is a biocompatible natural material that has a low degree of branch complexity. Agarose was chosen as the scaffold as it was proven that agarose offers a uniform environment and it does not contain any ionic charge (Kelly, Ng, Wang, Ateshian, & Hung, 2006). For this particular study that evaluates the effect of mechanical loading, it is important that the construct does not provide any additional factors (such as growth factors or anionic charges) besides the constructional matrix to hold the chondrocytes while their own ECM is produced as a results of the mechanical stimulation given.

Besides, Saris et al. (2000) has proven that dynamic pressure conduction through the agarose gel was thorough and prompt. In subsequent study run for 20 to 40 days on matrix composition and fine GAG structure by chondrocytes seeded in various type of scaffold that are commonly used in cartilage tissue engineering, chondrocytes were either seeded in degradable synthetic polymers- PGA, fibrillar protein gels- Collagen I and fibrin; agarose or alginate that is classified as polysaccharide gels. Due to the distinctive microstructure of molecular proteins and components in each scaffold used, chondrocytes seem to favour agarose. The highest sGAG to DNA ratio was produced by chondrocytes seeded in agarose, while those in alginate and collagen I had the lowest levels. In addition, agarose has shown an advantage over other types of scaffold in terms of the highest fraction of disulphated residues and the lowest amount of unsulfated residues, which nearly match the native articular cartilage (J.K. Mouw et al., 2007).

On the other hand, Hunter et al. (2004) has found that there is also a disadvantage of using a natural polymer as a scaffold. Using fibrin has shown an adverse effect on cells in their response to loading. This might be caused by different pathways or mechanotransduction resulting from the interaction between the newly-synthesized ECM molecular proteins and molecules readily available in the scaffold. It was suggested that using agarose would encourage the cells to produce/synthesize natural new pericellular matrix, which the cells can interact with. This natural/normal matrix will induce physiologically ECM receptors ($\alpha_2\beta_1$ integrins and CD44). When fibrins were used, collagens and hyaluronan bind to other type or molecules causing activation of other receptors ($\alpha_5\beta_1$ or $\alpha_v\beta_3$ integrins). This paranormal integrins activation might affect cellular response to mechanical stimuli.

Another similar study was designed based on the fact that cartilage contains abundant negatively charged aggrecan molecules such as Chondroitin-4-Sulphate, Chondroitin-6-Sulfate and Keratan Sulphate incorporation with positive ions in interstitial fluid give rise to osmotic swelling pressure. Villanueva (2009) adopt these natural properties of cartilage by integrating chondroitin sulphate to the scaffold. However, a negative effect was seen from this incorporation due to changes to the osmotic environment. It is essential to culture chondrocytes in the physiological osmotic environment of native cartilage, about 400mosM.

7.5.2. Relevance of Mechanical Loading Regimes

Research has been carried out to determine contact pressures experienced by human hip joint. During standing for a period of time, the pressure felt by the joint was measured to be 1MPa. While walking, the contact pressure ranging from 0.1 to 4MPa (J. Urban, 1994).

These values are translated to 10-20% compressive strain. There are some literatures published with 10% and 15% compressive strains (M. Buschmann et al., 1995; Chowdury et al., 2003; Davisson et al., 2002; D. Lee et al., 2000; RL Mauck et al., 2003; Shelton et al., 2003; Villanueva et al., 2009).

Despite high compressive amplitude done by other groups, for this particular study, amplitude of 5% compressive and shear strains was initially set to the test rig. This strain was less extensive than other studies stated previously, due to a study done by Waldman et al. (2007) that depicts equilibrium amplitude of compression and shear strain amplified the cells' ability to produce collagen and proteoglycan. Physiologically, the contact pressure experienced by human joint is not more than 5%.

However, considering the whole experiment that will take up to only 48 hours, as reported by Sah et al. (Sah et al., 1989), low frequency, low amplitude loading demonstrated less effect to the cells; amplitude of 10% compressive and 1% shear strains will be conveyed using the novel-design bioreactor.

The frequency was rationalized by studies that exposed chondrocytes to compressive strains at different frequencies (0.3, 1 or 3Hz). The results turn out to be highest GAG production by chondrocytes when exposed to 1Hz of stimulation (D. Lee et al., 2000; Shelton et al., 2003).

It was also found that repetitive cyclic compression applied in two 12 hours region gave better stimulation effect to the chondrocytes in comparison to chondrocytes that were subjected to continuous 24 hours of 15% (1Hz) compression (Chowdury et al., 2003).

7.5.3. DNA Measurement Protocol

A deoxyribonucleic acid (DNA) assay was utilized in the DNA analysis to determine cellular content. DNA measurement protocol were optimized to eliminate the difficulty of quantifying DNA content due to low cell density in articular cartilage and interference of other matrix components with DNA analysis (Hoemann, 2004; Y.-J. Kim et al., 1988; McGowan et al., 2002; M. R. Urban et al., 1998).

These studies have augmented a few ranges of excitation (355-365nm) and emission (450-460nm) wavelengths to detect the DNA content within the samples. It was also concluded that RNA level in the samples was not interfering the DNA content

quantification as the concentration of RNA was 400 times lower than that of DNA (McGowan et al., 2002).

7.5.4. Glycosaminoglycan Quantification Protocol

GAG is one of the earliest indications of chondrocyte metabolism. An optimised DMB assay was produced by Farndale (1982) to eliminate the instability of the assay where the GAG-DMB complexes tend to precipitate. The dye was stabilized by replacing the dibasic phosphate buffer with a formate buffer. The sGAG-DMB complex precipitation was impeded by its preparation without vigorous mixing and turbulence.

Furthermore, a modified form of DMB assay has improved its specificity towards sulphated GAGs. The specificity characteristic is attributed by lower pH and higher salt concentration of the new formulation of DMB, as it suppressed weak interactions between hyaluronic acid and DNA to DMB molecules. Besides, DMB analysis which previously almost always interfered by protein or glycoproteins in the ECM, can be avoided by sample digestion with papain prior to measuring (Richard W. Farndale, Buttle, & Barrett, 1986).

Chapter 8. Conclusion

8.1. Introduction

The chapter will suggest some possible mechanotransduction pathways activated by biaxial mechanical loads on chondrocytes. Some recommended future work on the cell system and mechanical loading regimes concludes this chapter.

8.2. Possible Mechanotransduction Pathways

Throughout the human body, there are various kinds of mechanical forces experienced by human beings, including gravity, tensile muscular forces, compressive loads, shear stresses and cyclically stretched (Wang & Thampatty, 2006). Cell behaviour and phenotype are governed by responses to mechanical forces, electrical stimuli and other physical cues. Transduction of mechanical stress into biochemical signals by cells is known as mechanotransduction. As explained in detail in Section 2.4.1, mechanotransduction may be studied at the molecular, cellular or the tissue level. Cell proliferation, ECM gene, protein expression and production of soluble factors are some of the responses of cells towards mechanical loading. However, it remains unclear how cells sense the forces and convert them to biological responses thereupon. There are many cellular components involved in mechanotransduction; the cytoskeleton, integrins, G proteins, receptor tyrosine kinases, mitogen-activated protein kinases and stretch-activated ion channels, to name a few.

Due to the complex structure of cartilage – anisotropic and heterogenic, there are multiple regulatory pathways activated by mechanical loading subjected to articular cartilage; upstream signalling, transcription, post-translational modification and

vesicular transport. Transcription and post-translational modifications of ECM molecules are affected as these processes involving ER and Golgi apparatus were seen to have changed their morphology and structure due to the load applied (Grodzinsky, Levenston, Jin, & Frank, 2000). Mechanical loading, such as simultaneous matrix stretch and compression, facilitates transportation of molecules and nutrients (M. Buschmann et al., 1995; M. Jin et al., 2001).

Signalling mechanisms due to cyclic loading involve actin cytoskeleton, stretch-activated ion channels and activation of tyrosine kinase (M. Jin et al., 2001; Millward-Sadler, Wright, Davies, Nuki, & Salter, 2000). Mechanical loads have shown to cause changes in cell shape and nucleus structure due to deformation of chondrocyte cytoskeletal components such as microtubules (MTs) and vimentin intermediate filaments (IFs) (C. Lee, Grad, Wimmer, & Alini, 2006). As mentioned in Section 1.1.1, MTs which forms basket-like mesh throughout cytoplasm is held responsible of intracytoplasmic transport. Organization of Golgi apparatus depends on MTs as depolymerisation of MTs leads to restructuring of Golgi membrane in ER. IFs were abundantly found at the weight bearing region of articular cartilage, indicating their involvement in mechanical as well as transport and signalling functions (Jortikka et al., 2000). Both MTs and vimentin IFs were detected even at the initial stage of culture period, suggesting that these structures retain during the isolation procedure (D. A. Lee et al., 2000).

In addition, vimentin IFs which can be found transverse from plasma membrane to the nuclear membrane are believed to mediate transcription for genomic DNA via nucleus deformation and sequence-specific DNA interactions (Langelier et al., 2000; C.

Lee et al., 2006; D. A. Lee et al., 2000). Besides IFs and MTs, the finest cytoskeletal component, actin microfilaments play roles in secretion and endocytosis. Actin microfilaments also provide structural protection to ECM proteins against shear stress (Langelier et al., 2000).

As a result of mechanical compression, matrix and chondrocytes go through deformation. This causes changes of cells and nucleus volume and surface area. However, dynamic compressions of specific mechanical regimes given with a resting period have caused the least deformation due to osmotic properties of cartilage tissue. Hydrodynamic forces results to individual chondrocytes to elongate and align tangential to the direction of fluid shear. Even the length of the GAG chains in human and bovine cartilage increased; thus enhanced its water retention capability (R. L. Smith et al., 1995). Collagen fibres entrapped the water molecules. Further compression will cause some of the fluid to be exudated. With less water content, the matrix is negatively charged due to the proteoglycan. This ionic difference has caused positive ion molecules such as Na^+ and Ca^{2+} to travel into the matrix. These ions have been shown to be essential to induce some metabolic behaviour of chondrocytes.

In addition, mechanical shear loading which leads to membrane stretch also change the orientation of collagen bundles which in turn rearrange cell, cytoskeletal actin microfilaments, microtubules and intermediate filaments and nucleus (Ingber, 2006; Mobasher et al., 2010; Salter & Lee, 2010). Cytoskeletal deformations may have triggered stretch-activated ion channels and integrin-cytoskeleton machinery which activates kinase cascades leading to changes in transcriptional regulation (Millward-Sadler & Salter, 2004). Hyperpolarisation of chondrocyte cell membranes actuates

stretch-activated ion channels that initiate the activation of Ca²⁺-dependent K⁺ ion channels (Wright, Jobanputra, Bavington, Salter, & Nuki, 1996). Membrane distortion due to shear loading is either directly affecting cytoskeletal distortion of transmembrane molecules or stretch-activated ion channels are linked to cytoskeleton via β_1 integrin (Ingber, 2006; Mobasheri et al., 2010). As stated in Section 2.2.4, integrin receptors act as the adhesion sites between chondrocytes and fibronectin. Fibronectin promotes cell attachment to the matrix and play an important role in cell motility and differentiation (Wang & Thampatty, 2006). Integrins are essential in regulating activation of a number of intracellular cascades that induce changes in gene expression and tissue remodelling. This is enhanced by the $\alpha_5\beta_1$ integrin-fibronectin binding via RGD (Arg-Gly-Asp) motifs, which specifically activate the mitogen-activated protein (MAP) kinase pathway (Kock et al., 2009; Millward-Sadler et al., 2000). There upon, activation of integrins due to shear loading leads to tyrosine phosphorylation of regulatory proteins and secretion of autocrine and paracrine acting soluble mediators, interleukin-4 (IL-4) (Millward-Sadler & Salter, 2004).

8.3. Future Work and Recommendation

8.3.1. Cell Work

Digestion Enzyme

Further study can be done to incorporate hyaluronidase to digest the hyaluronan, a type of GAG found in cartilage. Two-stage cartilage digestion using protease and a combination of type-XI and type-II collagenase can also be tested as it is known that type-XI collagen acts as the nucleation site for the deposition of type II collagen.

Protease will partially degrade the ECM, while degradation by type-XI collagenase will expose type-II collagen for better degradation.

Incubation Temperature

Each enzyme has an optimum temperature at which it works best. Increasing the enzyme concentration (at 37°C) would jeopardize the cell viability and enzyme activity. High temperature will also break some of the weak bonds in the cells and enzyme. This will induce thermal denaturation and eventually inactivate some of the proteins in the enzyme.

8.3.2. Mechanical Regimes

Long-Term Compression of Cell

A series of studies can be conducted to see the prolonged effect of mechanical stimulation on chondrocytes seeded in agarose constructs. Long-term experiments are needed to see the reaction of chondrocytes in terms of GAG production, DNA quantification, NO level and collagen production. Longer durations of mechanical loading exposure ranging from four to eight months should be used (RL Mauck et al., 2003; Waldman et al., 2007).

Besides, the mechanical regimes can be differentiated in terms of duration of exposure, waveform, frequency and strain magnitude. We recommend the normative use of 1 Hz trapezoidal loading for better cell proliferation and sinusoidal loading for high GAG production.

Real-time Imaging

To date, there have not been single studies that assess the metabolic and catabolic process of chondrocytes both temporally and spatially. Thus, it is crucial to incorporate an imaging apparatus to see the phenomena of the chondrocytes matrix during loading. Real-time imaging can be used to give some idea of cell processes chronologically. Besides, this additional characteristic can be enhanced with fluorescence imaging to examine signalling in a cartilage matrix that contributes to cartilage survival, and to scrutinize the interaction of organelles intracellularly (or perhaps intercellularly). Besides, matrix metalloproteinases (MMPs) should be assessed to confirm that these catabolic enzymes are not inhibiting metabolism process of articular cartilage while being exposed to biaxial compression.

References

- Abbot, A., Levine, W., & Mow, V. (2003). Biomechanics of The Articular Cartilage and Menisci of the Adult Knee. In J. Callaghan (Ed.), *The Adult Knee* (Vol. Volume 1, pp. 81-91). Philadelphia, PA: Lippincott Williams & Wilkins.
- Agrawal, C. M., & Ray, R. B. (2001). Biodegradable polymeric scaffolds for musculoskeletal tissue engineering. *Journal of Biomedical Materials Research*, 55(2), 141-150.
- Akanji, O. O., Lee, D. A., & Bader, D. A. (2008). The effects of direct current stimulation on isolated chondrocytes seeded in 3D agarose constructs. *Biorheology*, 45(3), 229-243.
- Alberts, B., Bray, D., Johnson, A., Julian, L., Raff, M., Roberts, K., & Walter, P. (1998). *Essential Cell Biology*. Union Square West, New York: Garland Publishing, Inc.
- Alberts, B., Johnson, A., & Lewis, J. (2002). *Molecular Biology of the Cell*. New York: Garland.
- Athanasίου, K. A., Darling, E. M., & Hu, J. C. (2009). Articular Cartilage Tissue Engineering. *Synthesis Lectures on Tissue Engineering*, 1(1), 1-182.
- Bader, D., & Lee, D. (2000). Structure - Properties of Soft Tissues Articular Cartilage. In M. Elices (Ed.), *Structural Biological Materials - Design and Structure Property Relationships* (pp. 73-100). Oxford: Elsevier Science Ltd.
- Baicu, S., & Taylor, M. (2002). Acid-base buffering in organ preservation solutions as a function of temperature: new parameters for comparing buffer capacity and efficiency. *Cryobiology*, 45, 33-48.
- Barbero, A., & Martin, I. (2007). Human articular chondrocyte culture. In H. Hauser (Ed.), *Tissue Engineering* (pp. 237-247). New Jersey: Humana Press.
- Benya, P. D., & Shaffer, J. D. (1982). Dedifferentiated chondrocytes reexpress the differentiated collagen phenotype when cultured in agarose gels. *Cell*, 30(1), 215-224.
- Bhosale, A. M., & Richardson, J. B. (2008). Articular cartilage: structure, injuries and review of management. *British Medical Bulletin*, 87(1), 77-95.
- Bonaventure, J., Kadhom, N., Cohen-Solal, L., Ng, K. H., Bourguignon, J., Lasselin, C., & Freisinger, P. (1994). Reexpression of Cartilage-Specific Genes by Dedifferentiated Human Articular Chondrocytes Cultured in Alginate Beads. *Experimental Cell Research*, 212(1), 97-104.
- Brittberg, M. (2008). Autologous chondrocyte implantation-technique and long term follow-up. *Injury International Journal of the Care of the Injured*, 39(Supp 1), S40-S49.
- Brown, T. A. (2002). Regulation of Genome Activity *Genomes* (Second ed.). Oxford: BIOS Scientific Ltd.
- Bryant, S. J., Chowdhury, T. T., Lee, D. A., Bader, D. L., & Anseth, K. S. (2004). Crosslinking Density Influences Chondrocyte Metabolism in Dynamically Loaded Photocrosslinked Poly(ethylene glycol) Hydrogels. *Annals of Biomedical Engineering*, 32(3), 407-417.
- Buckwalter, J., Hunziker, E., Rosenberg, L., Coutts, R., Adams, M., & Eyre, D. (1987). Articular Cartilage: Composition and Structure. In S. Woo & J. Buckwalter

- (Eds.), *Injury and Repair of the Musculoskeletal Soft Tissues* (pp. 405-424). Rosemont: American Academy of Orthopaedic.
- Buckwalter, J. A. (2005). Musculoskeletal Tissues and The Musculoskeletal System. In S. L. Weinstein & J. A. Buckwalter (Eds.), *Turek's Orthopaedics: Principles and Their Applications* (Fifth ed., pp. 26-31). Philadelphia, Pennsylvania: Lippincott Williams and Wilkins.
- Buckwalter, J. A., & Mankin, H. (1997a). Articular Cartilage Part 1: Tissue Design and Chondrocyte-Matrix Interaction. *Journal of Bone Joint Surgery (America)*, 79-A(4), 600-611.
- Buckwalter, J. A., & Mankin, H. (1997b). Articular Cartilage. Part II: Degeneration and Osteoarthritis, Repair, Regeneration and Transplantation. *Journal of Bone and Joint Surgery. American Volume*, 79-A(4), 612-632.
- Bueno, E., Laevsky, G., & Barabino, G. (2007). Enhancing cell seeding of scaffolds in tissue engineering through manipulation of hydrodynamic parameters. *Journal of biotechnology*, 129, 516-531.
- Buschmann, M., Gluzband, Y., Grodzinsky, A., & Hunziker, E. (1995). Mechanical compression modulates matrix biosynthesis in chondrocyte/agarose culture. *Journal of Cell Science* 108(Part 4), 1497-1508.
- Buschmann, M. D., Hunziker, E. B., Kim, Y. J., & Grodzinsky, A. J. (1996). Altered aggrecan synthesis correlates with cell and nucleus structure in statically compressed cartilage. *Journal of Cell Science*, 109(2), 499-508.
- Buschmann, M. D., Kim, Y.-J., Wong, M., Frank, E., Hunziker, E. B., & Grodzinsky, A. J. (1999). Stimulation of Aggrecan Synthesis in Cartilage Explants by Cyclic Loading Is Localized to Regions of High Interstitial Fluid Flow¹. *Archives of Biochemistry and Biophysics*, 366(1), 1-7.
- Carver, S., & Heath, C. (1999). Semi-continuous perfusion system for delivering intermittent physiological pressure regenerating cartilage. *Tissue Eng*, 5(1), 1-11.
- Chai, D. H., Arner, E. C., Griggs, D. W., & Grodzinsky, A. J. (2010). α v and β 1 integrins regulate dynamic compression-induced proteoglycan synthesis in 3D gel culture by distinct complementary pathways. *Osteoarthritis and Cartilage*, 18(2), 249-256.
- Chao, P.-h. G., West, A. C., & Hung, C. T. (2006). Chondrocyte intracellular calcium, cytoskeletal organization, and gene expression responses to dynamic osmotic loading. *Am J Physiol Cell Physiol*, 291(4), C718-725.
- Chen, A. C., Bae, W. C., Schinagl, R. M., & Sah, R. L. (2001). Depth- and strain-dependent mechanical and electromechanical properties of full-thickness bovine articular cartilage in confined compression. *Journal of Biomechanics*, 34(1), 1-12.
- Chowdury, T., Bader, D., Shelton, J., & Lee, D. (2003). Temporal regulation of chondrocyte metabolism in agarose constructs subjected to dynamic compression. *Archives of Biochemistry and Biophysics*, 417, 105-111.
- Cooper, J., Li, W., Bailey, L., Hudson, S., Lin-Gibson, S., Anseth, K., . . . Washburn, N. (2007). Encapsulated chondrocyte response in a pulsatile flow bioreactor. *Acta Biomaterialia*, 3(1), 13-21.
- Cotran, R. S., Kumar, V., & Collins, T. (1999). *Pathologic Basic of Disease* (6 ed.). Philadelphia: W.B. Saunders.

- Davisson, T., Kunig, S., Chen, A., Sah, R., & Ratcliffe, A. (2002). Static and dynamic compression modulate matrix metabolism in tissue engineered cartilage. *Journal of Orthopaedic Research*, 20(4), 842-848.
- Di Cesare, P. E., Chen, F. S., Moergelin, M., Carlson, C. S., Leslie, M. P., Perris, R., & Fang, C. (2002). Matrix-matrix interaction of cartilage oligomeric matrix protein and fibronectin. *Matrix Biology*, 21(5), 461-470.
- DiMicco, M., Kisiday, J., Gong, H., & Grodzinsky, A. (2007). Structure of pericellular matrix around agarose-embedded chondrocytes. *Osteoarthritis and Cartilage*, 15, 1207-1216.
- Doherty, M., Lanyon, P., & Ralston, S. H. (2002). Musculoskeletal Disorders. In C. Haslett, E. Chilvers, N. Boon & N. Colledge (Eds.), *Davidson's Principles and Practice of Medicine* (19 ed., pp. 965-1003). Edinburgh: Churchill Livingstone.
- Enobakhare, B. O., Bader, D. L., & Lee, D. A. (1996). Quantification of Sulfated Glycosaminoglycans in Chondrocyte/Alginate Cultures, by Use of 1,9-Dimethylmethylene Blue. *Analytical Biochemistry*, 243, 189-191.
- Estes, B. T., Gimble, J. M., & Guilak, F. (2004). Mechanical signals as regulators of stem cell fate. In G. P. Schatten (Ed.), *Stem Cells in Development and Disease* (pp. 97-122). San Diego: Elsevier Academic Press.
- Eyre, D. (2001). Collagen of articular cartilage. *Arthritis Research and Therapy*, 4(1), 30-35.
- Eyre, D. (2002). Articular cartilage and changes in Arthritis: Collagen of articular cartilage. *Arthritis Research and Therapy*, 4(1), 30 - 35.
- Fan, J., & Waldman, S. (2010). The Effect of Intermittent Static Biaxial Tensile Strains on Tissue Engineered Cartilage. *Ann Biomed Eng*, 38(4), 1672-1682.
- Farach-Carson, M., Wagner, R., & Kiick, K. (2006). Extracellular Matrix : Structure, Function and Applications to Tissue Engineering. In J. Bronzino (Ed.), *The Biomedical Engineering Handbook : Tissue Engineering and Artificial Organs*. Boca Raton: CRC Press.
- Farach-Carson, M., Wagner, R., & Kiick, K. (2007). Extracellular matrix: Structure, Function and Applications to Tissue Engineering. In J. P. Fisher, A. Mikos & J. Bronzino (Eds.), *Tissue Engineering* (pp. 1-15). Boca Raton: CRC Press.
- Farndale, R. W., Buttle, D. J., & Barrett, A. J. (1986). Improved quantitation and discrimination of sulphated glycosaminoglycans by use of dimethylmethylene blue. *Biochimica et Biophysica Acta*, 883(2), 173-177.
- Farndale, R. W., Sayers, C. A., & Barrett, A. J. (1982). A Direct Spectrophotometric Microassay For Sulfated Glycosaminoglycans in Cartilage Cultures. *Connective Tissue Research*, 9, 247-248.
- Federica, B., Giancarlo, P., Francesca, G., Giuseppe, M. P., & Gabriele, D. (2004). Biomechanical properties of human articular cartilage under compressive loads. *Biorheology*, 41(3), 159-166.
- Frank, E. H., Jin, M., Loening, A. M., Levenston, M. E., & Grodzinsky, A. (2000). A versatile shear and compression apparatus for mechanical stimulation of tissue culture explants. *Journal of Biomechanics*, 33, 1523-1527.
- Frohlich, M., Malicev, E., Gorenssek, M., Knezevic, M., & Kregar Velikonja, N. (2007). Evaluation of rabbit auricular chondrocyte isolation and growth parameters in cell culture. *Cell Biology International Reports*, 31, 620-625.
- Gartner, L., Hiatt, J., & Strum, J. (2006). *Cell Biology and Histology* (5 ed.). Philadelphia: Lippincott Williams and Wilkins.

- Gemmiti, C., & Guldberg, R. (2006). Fluid flow increases Type-II collagen deposition and tensile mechanical properties in bioreactor-grown tissue-engineered cartilage. *Tissue Eng*, 12(3), 469-479.
- Gendelman, R., Burton-Wurster, N. I., MacLeod, J. N., & Lust, G. (2003). The cartilage-specific fibronectin isoform has a high affinity binding site for the small proteoglycan decorin. *Journal of Biological Chemistry*, 278(13), 11175-11181.
- Giannoni, P., & Cancedda, R. (2006). Articular cartilage culturing for cell-based cartilage repair: Needs and Perspectives. *Cells Tissues Organs*, 184, 1-15.
- Goldberg, R. L., & Kolibas, L. M. (1990). An Improved Method for Determining Proteoglycans Synthesized by Chondrocytes in Culture. *Connective Tissue Research*, 24(3-4), 265-275.
- Goldring, M. B., Sandell, L. J., Stephenson, M. L., & Krane, S. M. (1986). Immune interferon suppresses levels of procollagen mRNA and type II collagen synthesis in cultured human articular and costal chondrocytes. *Journal of Biological Chemistry*, 261(19), 9049-9055.
- Grad, S., Lee, C. R., Gorna, K., Gogolewski, S., Wimmer, M. A., & Alini, M. (2005). Surface Motion Upregulates Superficial Zone Protein and Hyaluronan Production in Chondrocyte-Seeded Three-Dimensional Scaffolds. *Tissue Eng*, 11(1-2), 249-256.
- Grad, S., Lee, C. R., Wimmer, M. A., & Alini, M. (2006). Chondrocyte gene expression under applied surface motion. *Biorheology*, 43(3), 259-269.
- Grodzinsky, A. J., Levenston, M. E., Jin, M., & Frank, E. H. (2000). Cartilage tissue remodeling in response to mechanical forces. *Annual Review of Biomedical Engineering*, 2(1), 691-713.
- Guilak, F., Meyer, B. C., Ratcliffe, A., & Mow, V. C. (1994). The effects of matrix compression on proteoglycan metabolism in articular cartilage explants. *Osteoarthritis and Cartilage*, 2(2), 91-101.
- Guilak, F., & Mow, V. C. (2000). The mechanical environment of the chondrocyte: a biphasic finite element model of cell-matrix interactions in articular cartilage. *Journal of Biomechanics*, 33(12), 1663-1673.
- Guilak, F., Ratcliffe, A., & Mow, V. C. (1995). Chondrocyte deformation and local tissue strain in articular cartilage: a confocal microscopy study. *J. Orthop. Res.*, 13(3), 410-421.
- Hansen, U., Schunke, M., Domm, C., Ioannidis, N., Hassenpflug, J., Gehrke, T., & Kurz, B. (2001). Combination of reduced oxygen tension and intermittent hydrostatic pressure: a useful tool in articular cartilage tissue engineering. *Journal of Biomechanics*, 34, 941-949.
- Hart, J. A. L., & Miller, R. K. (2004). Articular Cartilage: Biomechanics, Injury and Surgical Treatment of Defects. In D. Poytout (Ed.), *Biomechanics and Biomaterials in Orthopedics* (pp. 229-232). London: Springer.
- Hayman, D., Blumberg, T., C, S., & Athanasiou, K. (2006). The effect of isolation on chondrocyte gene expression. *Tissue Engineering*, 12(9), 2573-2581.
- Heiner, A. D., & Martin, J. A. (2004). Cartilage responses to a novel triaxial mechanostimulatory culture system. *J. Biomech.*, 37(5), 689-695.
- Helfrich, M. H., & Horton, M. A. (2006). Integrins and Other Adhesion Molecules. In M. J. Seibel, S. P. Robins & J. P. Bilezikian (Eds.), *Dynamics of Bone and Cartilage Metabolism* (pp. 142-143). San Diego: Academic Press.

- Hern, D. L., & Hubbell, J. A. (1998). Incorporation of adhesion peptides into nonadhesive hydrogels useful for tissue resurfacing. *Journal of Biomedical Materials Research*, 39(2), 266-276.
- Heywood, H. K., Sembi, P. K., Lee, D. A., & Bader, D. L. (2004). Cellular Utilization Determines Viability and Matrix Distribution Profiles in Chondrocyte-Seeded Alginate Constructs. *Tissue Eng*, 10(9-10), 1467-1479.
- Hidvegi, N., Sales, K., Izadi, D., Ong, J., Kellam, P., Eastwood, D., & Butler, P. (2006). A low temperature method of isolating normal human articular chondrocytes. *Osteoarthritis and Cartilage*, 14, 89-93.
- Hoemann, C. (2004). Molecular and Biochemical Assays of Cartilage Components. In D. F. Ceuninck, M. Sabatini & P. Pastoureau (Eds.), *Methods in Molecular Medicine: Cartilage and Osteoarthritis* (Vol. Volume 2: Structure and In Vivo Analysis, pp. 127-152). Totowa, NJ: Humana Press Inc.
- Holden, P., Meadows, R., Chapman, K., Grant, M., Kadler, K., & Briggs, M. (2001). Cartilage oligomeric matrix protein interacts with type-XI collagen, and disruptions to these interactions identify a pathogenetic mechanism in a bone dysplasia family. *Journal of Biological Chemistry*, 276, 6046-6055.
- Hunter, C. J., Mouw, J. K., & Levenston, M. E. (2004). Dynamic compression of chondrocyte-seeded fibrin gels: effects on matrix accumulation and mechanical stiffness. *Osteoarthritis and Cartilage* 12(2), 117-130.
- Huselstein, C., de Isla, N., Kolopp-Sarda, M. N., Kerdjoudj, H., Muller, S., & Stoltz, J. F. (2006). Influence of mechanical stress on cell viability. *Biorheology*, 43(3), 371-375.
- Hyun, W. K., & Chang, D. H. (2000). An Overview of Cartilage Tissue Engineering. *Yonsei Medical Journal*, 41(6), 766-773.
- Ikenoue, T., Trindade, M., Lee, M. S., Lin, E. Y., Schurman, D., Goodman, S., & Smith, R. (2003). Mechanoregulation of human articular chondrocyte aggrecan and type II collagen expression by intermittent hydrostatic pressure in vitro. *J. Orthop. Res.*, 21(1), 110-116.
- Ingber, D. E. (2006). Cellular mechanotransduction: putting all the pieces together again. *The FASEB Journal*, 20(7), 811-827.
- Iozzo, R. (2000). Introductory Remarks and Overview. In R. Iozzo (Ed.), *Proteoglycans: Structure, Biology and Molecular Interactions* (pp. 1). New York: Marcel Dekker Inc.
- Jennifer, H. L., John, K., & Alan, J. G. (2003). Tissue-Engineered Versus Native Cartilage: Linkage between Cellular Mechano-Transduction and Biomechanical Properties. In G. Bock & J. Goode (Eds.), *Tissue Engineering of Cartilage and Bone* (pp. 52-69).
- Jin, G., Sah, R. L., Li, Y. S., Lotz, M., Shyy, J. Y. J., & Chien, S. (2000). Biomechanical regulation of matrix metalloproteinase-9 in cultured chondrocytes. *Journal of Orthopaedic Research*, 18(6), 899-908.
- Jin, M., Frank, E. H., Quinn, T. M., Hunziker, E., & Grodzinsky, A. (2001). Tissue shear deformation stimulates proteoglycan and protein biosynthesis in bovine cartilage explants. *Archives of Biochemistry and Biophysics*, 395, 41-48.
- Johnson, B., & Christensen, L. (2010). *Educational Research: Quantitative, Qualitative and Mixed Approaches*. Thousand Oaks, CA: SAGE Publications Inc.
- Jortikka, M. O., Parkkinen, J. J., Inkinen, R. I., Kärner, J., Järveläinen, H. T., Nelimarkka, L. O., . . . Lammi, M. J. (2000). The Role of Microtubules in the

- Regulation of Proteoglycan Synthesis in Chondrocytes under Hydrostatic Pressure. *Arch. Biochem. Biophys.*, 374(2), 172-180.
- Jurvelin, J. S., Buschmann, M. D., & Hunziker, E. B. (1997). Optical and mechanical determination of poisson's ratio of adult bovine humeral articular cartilage. *Journal of Biomechanics*, 30(3), 235-241.
- Kelly, T.-A. N., Ng, K. W., Wang, C. C. B., Ateshian, G. A., & Hung, C. T. (2006). Spatial and temporal development of chondrocyte-seeded agarose constructs in free-swelling and dynamically loaded cultures. *Journal of Biomechanics*, 39(8), 1489-1497.
- Kiani, C., Chen, L., Wu, Y.-J., Yee, A., & Yang, B. (2002). Structure and function of aggrecan. *Cell Research*, 12(1), 19-32.
- Kim, H. W., & Han, C. D. (2000). An overview of cartilage tissue engineering. *Yonsei Medical Journal*, 41(6), 766-773.
- Kim, Y.-J., Sah, R. L. Y., Doong, J.-Y. H., & Grodzinsky, A. J. (1988). Fluorometric assay of DNA in cartilage explants using Hoechst 33258. *Analytical Biochemistry*, 174(1), 168-176.
- Kim, Y., Bonassar, L. J., & Grodzinsky, A. (1995). The role of cartilage streaming potential, fluid flow and pressure in the stimulation of chondrocyte biosynthesis during dynamic compression. *Journal of Biomechanics*, 28(9), 1055-1066.
- Knight, M. M., Ghorri, S. A., Lee, D. A., & Bader, D. L. (1998). Measurement of the deformation of isolated chondrocytes in agarose subjected to cyclic compression. *Medical Engineering and Physics*, 20(9), 684-688.
- Knight, M. M., Toyoda, T., Lee, D. A., & Bader, D. L. (2006). Mechanical compression and hydrostatic pressure induce reversible changes in actin cytoskeletal organisation in chondrocytes in agarose. *Journal of Biomechanics*, 39(8), 1547-1551.
- Kock, L. M., Schulz, R. M., van Donkelaar, C. C., Thümmeler, C. B., Bader, A., & Ito, K. (2009). RGD-dependent integrins are mechanotransducers in dynamically compressed tissue-engineered cartilage constructs. *Journal of Biomechanics*, 42(13), 2177-2182.
- Korossis, S., Bolland, F., Kearny, J., Fisher, J., & Ingham, E. (2005). Bioreactors in tissue engineering. In N. Ashammakhi, R. Reis & E. Chiellini (Eds.), *Topics in tissue engineering* (Vol. 3, pp. 1-23). Finland: University of Oulu.
- Langelier, E., Suetterlin, R., Hoemann, C. D., Aebi, U., & Buschmann, M. D. (2000). The Chondrocyte Cytoskeleton in Mature Articular Cartilage: Structure and Distribution of Actin, Tubulin, and Vimentin Filaments. *J. Histochem. Cytochem.*, 48(10), 1307-1320.
- Langer, R., & Vacanti, J. P. (1993). Tissue Engineering. *Science*, 260(5110), 920-923.
- Lee, C., Grad, S., Wimmer, M., & Alini, M. (2006). The Influence of Mechanical Stimuli on Articular Cartilage Tissue Engineering. In N. Ashammakhi & R. L. Reis (Eds.), *Topics in Tissue Engineering* (Vol. 2, pp. 1-32). Finland: University of Oulu.
- Lee, D., Noguchi, T., Frean, S., Lees, P., & Bader, D. (2000). The influence of mechanical loading on isolated chondrocytes seeded in agarose constructs. *Biorheology*, 37, 149-161.
- Lee, D. A., Knight, M. M., F. Bolton, J., Idowu, B. D., Kayser, M. V., & Bader, D. L. (2000). Chondrocyte deformation within compressed agarose constructs at the cellular and sub-cellular levels. *J Biomech* 33(1), 81-95.

- Lee, M. S., Trindade, M. C. D., Ikenoue, T., Schurman, D. J., Goodman, S. B., & Smith, R. L. (2002). Effects of shear stress on nitric oxide and matrix protein gene expression in human osteoarthritic chondrocytes in vitro. *J Orthop Res*, 20(3), 556-561.
- Lindahl, A., Brittberg, M., & Peterson, L. (2003). Cartilage Repair with Chondrocytes: Clinical and Cellular Aspects. In G. Bock & J. Goode (Eds.), *Tissue Engineering of Cartilage and Bone* (pp. 175-184). West Sussex: John Wiley & Sons Ltd.
- Lodish, H., Berk, A., Baltimore, D., Zipursky, S. L., Matsudaira, P., & Darnell, J. (2000). Integrating Cells into Tissues *Molecular Cell Biology*. San Francisco: W.H. Freeman and Co.
- Lohmander, S. (2003). Tissue Engineering of Cartilage: Do we need it, can we do it, is it good and can we prove it? *Tissue Engineering of Cartilage and Bone* (1 ed., pp. 2-9). West Sussex: John Wiley & Sons Ltd.
- Loret, B., & Simões, F. M. F. (2007). Articular cartilage with intra- and extrafibrillar waters - mass transfer and generalized diffusion. *European Journal of Mechanics - A/Solids*, 26(5), 759-788.
- Lucchinetti, E., Bhargava, M., & Torzilli, P. (2004). The effect of mechanical load on integrin subunits $\alpha 5$ and $\beta 1$ in chondrocytes from mature and immature cartilage explants. *Cell and Tissue Research*, 315(3), 385-391.
- Macdonald, A. G. (2002). Ion channels under high pressure. *Comparative Biochemistry and Physiology* 131(3), 587-593.
- Mankin, H., Mow, V., Buckwalter, J., Lannotti, J., & Ratcliffe, A. (1994). Form and Function of Articular Cartilage. In S. Simon (Ed.), *Orthopaedic Basic Science* (pp. 3-44). Iowa City: American Academy of Orthopaedic Surgeons.
- Mansour, J. M. (2003). Biomechanics of Cartilage. In C. A. Oatis (Ed.), *Kinesiology: The Mechanics and Pathomechanics of Human Movement* (pp. 66-79). Philadelphia: Lippincott Williams and Wilkins.
- Martin, I., Shastri, V. P., Padera, R. F., Yang, J., Mackay, A. J., Langer, R., . . . Freed, L. E. (2001). Selective differentiation of mammalian bone marrow stromal cells cultured on three-dimensional polymer foams. *Journal of Biomedical Materials Research*, 55(2), 229-235.
- Martin, I., Wendt, D., & Heberer, M. (2004). The role of bioreactors in tissue engineering. *Trends in Biotechnology*, 22(2), 80-86.
- Massachusetts Institute of Technology, M. (2006). Math Model Could Aid Study of Collagen Ailments. *ScienceDaily* Retrieved Jan 22, 2010, 2010, from <http://www.sciencedaily.com/releases/2006/11/061114190020.htm>
- Mauck, R., Soltz, M., Wang, C., Wong, D., Chao, P.-H., Valhmu, W., . . . Gerard, A. (2000). Functional Tissue Engineering of Articular Cartilage Through Dynamic Loading of Chondrocyte-Seeded Agarose. *Journal of Biomechanical Engineering*, 122(3), 252-260.
- Mauck, R., Wang, C., Oswald, E., Atheshian, G., & Hung, C. (2003). The role of cell seeding density and nutrient supply for articular cartilage tissue engineering with deformational loading. *Osteoarthritis Cartilage*, 11, 879-890.
- Mauck, R. L., Seyhan, S. L., Atheshian, G. A., & Hung, C. T. (2002). Influence of Seeding Density and Dynamic Deformational Loading on the Developing Structure/Function Relationships of Chondrocyte-Seeded Agarose Hydrogels. *Annals of Biomedical Engineering*, 30(8), 1046-1056.

- McGowan, K. B., Kurtis, M. S., Lottman, L. M., Watson, D., & Sah, R. L. (2002). Biochemical quantification of DNA in Human Articular and Septal Cartilage using PicoGreen and Hoechst 33258. *Osteoarthritis and Cartilage*, *10*, 580-587.
- McMahon, L., Reid, A., Campbell, V., & Prendergast, P. (2008). Regulatory Effects of Mechanical Strain on the Chondrogenic Differentiation of MSCs in a Collagen-GAG Scaffold: Experimental and Computational Analysis. *Annals of Biomedical Engineering*, *36*(2), 185-194.
- Meyer, U. (2009). The History of Tissue Engineering and Regenerative Medicine in Perspective. In U. Meyer, J. Handschel, T. Meyer & H. P. Wiesmann (Eds.), *Fundamentals of Tissue Engineering and Regenerative Medicine* (pp. 5-10). Berlin Heidelberg: Springer-Verlag.
- Michels, C. (2002). *Genetic Techniques for Biological Research: A Case Study Approach*. West Sussex: John Wiley & Sons, Ltd.
- Millward-Sadler, S. J., & Salter, D. M. (2004). Integrin-Dependent Signal Cascades in Chondrocyte Mechanotransduction. *Annals of Biomedical Engineering*, *32*(3), 435-446.
- Millward-Sadler, S. J., Wright, M. O., Davies, L. W., Nuki, G., & Salter, D. M. (2000). Mechanotransduction via integrins and interleukin-4 results in altered aggrecan and matrix metalloproteinase 3 gene expression in normal, but not osteoarthritic, human articular chondrocytes. *Arthritis Rheum* *43*(9), 2091-2099.
- Minuth, W. W., Strehl, R., & Schumacher, K. (2005). *Tissue Engineering*. Weinheim: Wiley-VCH Verlag GmBH & Co.
- Mobasheri, A., Barret-Jolley, R., Carter, S. D., Martin-Vasallo, P., Schulze-Tanzil, G., & Shakibaei, M. (2005). Functional Roles of Mechanosensitive Ion Channels, β 1 Integrins and Kinase Cascades. In A. Kamkin & I. Kiseleva (Eds.), *Chondrocyte Mechanotransduction, Mechanosensitivity in Cells and Tissues*. Moscow: Academia Publishing House Ltd.
- Mobasheri, A., Lewis, R., Maxwell, J. E. J., Hill, C., Womack, M., & Barrett-Jolley, R. (2010). Characterization of a stretch-activated potassium channel in chondrocytes. *Journal of Cellular Physiology*, *223*(2), 511-518.
- Morse, A. (2009). Services for People with Rheumatoid Arthritis (H. o. Commons, Trans.) (pp. 14). London: Naitonal Audit Office.
- Mouw, J. K., Case, N. D., Guldborg, R. E., Plaas, A. H. K., & Levenston, M. E. (2005). Variations in matrix composition and GAG fine structure among scaffolds for cartilage tissue engineering. *Osteoarthritis and Cartilage*, *13*(9), 828-836.
- Mouw, J. K., Imler, S. M., & Levenston, M. E. (2007). Ion-channel regulation of chondrocyte matrix synthesis in 3D culture under static and dynamic compression. *Biomechanics and Modeling in Mechanobiology*, *6*(1-2), 33-41.
- Mow, V., Fithian, D., & M, K. (1990). Fundamentals of Articular Cartilage and Meniscus Biomechanics. In J. Ewing (Ed.), *Articular Cartilage and Knee Joint Function: Basic Science and Arthroscopy*. New York: Raven Press Ltd.
- Mülhardt, C. (2007). Fundamental Methods *Molecular biology and genomics* (pp. 25). Burlington, MA: Academic Press.
- Muir, H. (1995). The chondrocyte, architect of cartilage. Biomechanics, structure, function and molecular biology of cartilage matrix macromolecules. *Bioessays*, *17*(12), 1039-1048.
- Naumann, A., Dennis, J., Aigner, J., Coticchia, J., Arnold, J., Berghaus, A., . . . Caplan, A. (2004). Tissue Engineering of Autologous Cartilage Grafts in Three-

- Dimensional in Vitro Macroaggregate Culture System. *Tissue Engineering*, 10(11-12), 1695-1706.
- Nguyen, B. V., Wang, Q. G., Kuiper, N. J., El Haj, A. J., Thomas, C. R., & Zhang, Z. (2010). Biomechanical properties of single chondrocytes and chondrons determined by micromanipulation and finite-element modelling. *Journal of The Royal Society Interface*, 7(53), 1723-1733.
- Oswald, E., Chao, P.-H., Bulinski, J., Ateshian, G., & Hung, C. (2008). Dependence of Zonal Chondrocyte Water Transport Properties on Osmotic Environment. *Cellular and Molecular Bioengineering*, 1(4), 339-348.
- Parry, V. (2005, May 21, 2005). Lend me your ear, *The Sunday Times*. Retrieved from <http://www.timesonline.co.uk/tol/news/uk/health/article524291.ece>
- Paulsson, M., Morgelin, M., Wiedermann, H., Beardmore-Gray, M., Dunham, D., Heinegard, D., . . . Engel, J. (1987). Extended and globular protein domains in cartilage proteoglycans. *Biochemistry Journal*, 245(3), 763-772.
- Pingguan-Murphy, B., El-Azzeh, M., Bader, D. L., & Knight, M. M. (2006). Cyclic compression of chondrocytes modulates a purinergic calcium signalling pathway in a strain rate- and frequency-dependent manner. *J Cell Physiol* 209(2), 389-397.
- Pingguan-Murphy, B., Lee, D., Bader, D., & Knight, M. (2005). Activation of chondrocytes calcium signalling by dynamic compression is dependent of number of cycles. *Archives of Biochemistry and Biophysics*, 444(1), 45-51.
- Pitha, J. (1978). Reagents Specific for Cell Surface Components. *European Journal of Biochemistry*, 82(1), 285-292.
- Porth, C. (2007). Structure and Function of Skeletal Systems *Essentials of pathophysiology: Concepts of altered health states* (pp. 970). Philadelphia: Lippincott Williams & Wilkins.
- Quinn, T. M., Schmid, P., Hunziker, E. B., & Grodzinsky, A. J. (2002). Proteoglycan deposition around chondrocytes in agarose culture: Construction of a physical and biological interface for mechanotransduction in cartilage. *Biorheology*, 39(1), 27-37.
- Ringe, J., & Sittinger, M. (2009). Tissue engineering in the rheumatic diseases. *Arthritis Research and Therapy*, 11(1).
- Roberts, S. R., Knight, M. M., Lee, D. A., & Bader, D. L. (2001). Mechanical compression influences intracellular Ca²⁺ signaling in chondrocytes seeded in agarose constructs. *Journal of Applied Physiology*, 90(4), 1385-1391.
- Robling, A. G., Hinant, F. M., Burr, D. B., & Turner, C. H. (2002). Improved Bone Structure and Strength After Long-Term Mechanical Loading Is Greatest if Loading Is Separated Into Short Bouts. *Journal of Bone and Mineral Research*, 17(8), 1545-1554.
- Rowley, J. A., & Mooney, D. J. (2002). Alginate type and RGD density control myoblast phenotype. *Journal of Biomedical Materials Research*, 60(2), 217-223.
- Rubin, A. (2009). *Statistics for Evidence-Based Practice and Evaluation*. Belmont, CA: Brooks/Cole.
- Saadeh, P. B., Brent, B., Mehrara, B. J., Steinbrech, D. S., Ting, V., Gittes, G. K., & Longaker, M. T. (1999). Human cartilage engineering: chondrocyte extraction, proliferation and characterization for construct development. *Annals of Plastic Surgery*, 42(5), 509-513.

- Sabatini, M., Pastoureau, P., Ceuninck, F., Thirion, S., & Berenbaum, F. (2004). Culture and Phenotyping of Chondrocytes in Primary Culture. In J. M. Walker (Ed.), *Cartilage and Osteoarthritis* (Vol. 100, pp. 1-14): Humana Press.
- Sah, R., Kim, Y., Doong, J., Grodzinsky, A., Plaas, A., & Sandy, J. (1989). Biosynthetic response of cartilage explants to dynamic compression. *J. Orthop. Res.*, 7, 619-636.
- Salter, D. M., & Lee, H.-S. (2010). Mechanical Signalling in Osteoarticular Tissues. *Journal of Medical Science*, 30(4), 141-147.
- Saris, D. B. F., Mukherjee, N., Berglund, L. J., Schultz, F. M., An, K.-N., & O'Driscoll, S. W. (2000). Dynamic Pressure Transmission Through Agarose Gels. *Tissue Eng*, 6(5), 531-537.
- Scheffler, I. (1999). *Mitochondria*. New York: John Wiley & Sons, Inc.
- Schuler, H., Karlsson, R., Schutt, C., & Lindberg, U. (2006). The Connection Between Actin ATPase and Polymerization. In S. Khurana (Ed.), *Aspects of the Cytoskeleton* (Vol. 37, pp. 49-50). San Diego: Elsevier.
- Schulz, R., & Bader, A. (2007). Cartilage tissue engineering and bioreactor systems for the cultivation and stimulation of chondrocytes. *European Biophysics Journal*, 36, 539-568.
- Schulz, R. M., Wustneck, N., Donkelaar, C. C. v., Shelton, J. C., & Bader, A. (2008). Development and validation of a novel bioreactor system for load- and perfusion-controlled tissue engineering of chondrocyte-construct. *Biotechnology and Bioengineering*, 101(4), 714-728.
- Seidel, J. O., Pei, M., Gray, M. L., Langer, R., Freed, L. E., & Vunjak-Novakovic, G. (2004). Long-term culture of tissue engineered cartilage in a perfused chamber with mechanical stimulation. *Biorheology*, 41(3), 445-458.
- Sharma, G., Saxena, R. K., & Mishra, P. (2007). Differential effects of cyclic and static pressure on biochemical and morphological properties of chondrocytes from articular cartilage. *Clinical Biomechanics*, 22(2), 248-255.
- Shelton, J. C., Bader, D. L., & Lee, D. A. (2003). Mechanical conditioning influences the metabolic response of cell-seeded constructs. *Cells, Tissues, Organs*, 175(3), 140-150.
- Shindle, M. K., Li, F. F., Kelly, B. T., & Potter, H. G. (2010). Articular Cartilage. In A. J. Khanna (Ed.), *MRI for Orthopaedic Surgeons* (pp. 353). New York: Thieme Publisher.
- Shiu, Y.-T. (2007). Mechanical forces on cells. In J. P. Fisher, A. Mikos & J. Bronzino (Eds.), *Tissue Engineering* (pp. 1-15). Boca Raton: CRC Press.
- Sims, C. D., Butler, P. E., Casanova, R., Lee, B. T., Randolph, M. A., Lee, W. P., . . . Yaremchuk, M. J. (1996). Injectable cartilage using polyethylene oxide polymer substrates. *Plastic and Reconstructive Surgery*, 98, 843 - 850.
- Smith, R., Lin, J., Trindade, M., Shida, J., Kajiyama, G., Vu, T., . . . Carter, D. (2000). Time-dependent effects of intermittent hydrostatic pressure on articular chondrocyte type II collagen and aggrecan mRNA expression. *Journal of Rehabilitation Research and Development*, 37(2), 153-161.
- Smith, R., Trindade, M., Ikenoue, T., Mohtai, M., Das, P., Carter, D., . . . Schurman, D. (2000). Effects of shear stress on articular cartilage metabolism. *Biorheology*, 37, 95-107.
- Smith, R. L., Donlon, B. S., Gupta, M. K., Mohtai, M., Das, P., Carter, D. R., . . . Schurman, D. J. (1995). Effects of fluid-induced shear on articular chondrocyte

- morphology and metabolism in vitro. *Journal of Orthopaedic Research*, 13(6), 824-831.
- Stockwell, R. (1979). Biology of Cartilage Cells. In R. Harrison & R. McMin (Eds.), *Biological Structure and Function* (Vol. 7, pp. 101-102). Cambridge: Cambridge University Press.
- Stoddart, M. J., Ettinger, L., & Häuselmann, H. J. (2006). Enhanced matrix synthesis in de novo, scaffold free cartilage-like tissue subjected to compression and shear. *Biotechnology and Bioengineering*, 95(6), 1043-1051.
- Szafranski, J. D., Grodzinsky, A. J., Burger, E., Gaschen, V., Hung, H.-H., & Hunziker, E. B. (2004). Chondrocyte mechanotransduction: effects of compression on deformation of intracellular organelles and relevance to cellular biosynthesis. *Osteoarthritis and Cartilage*, 12(12), 937-946.
- Temenoff, J., & Mikos, A. (2000). Review: tissue engineering for regeneration of articular cartilage. *Biomaterials*, 21, 431-440.
- Teng, M.-k., Usman, N., Frederick, C. A., & Wang, A. H. J. (1988). The molecular structure of the complex of Hoechst 33258 and the DNA dodecamer d(CGCGAATTCGCG). *Nucleic Acids Research*, 16(6), 2671-2690.
- Thoney, M. (2005). Body Composition: Breed and Species. In W. Pond & A. Bell (Eds.), *Encyclopedia of Animal Science* (pp. 155-160). New York: Marcel Dekker.
- Tuan, R., Boland, G., & Tuli, R. (2003). Adult mesenchymal stem cells and cell-based tissue engineering. *Arthritis Research and Therapy*, 5, 32 - 45.
- Tuli, R., Li, W.-J., & Tuan, R. (2003). Current state of cartilage tissue engineering. *Arthritis Research and Therapy*, 5(5), 235 - 238.
- Tuli, R., Seghatoleslami, M. R., Tuli, S., Wang, M. L., Hozack, W. J., Manner, P. A., . . . Tuan, R. S. (2003). A simple, high-yield method for obtaining multipotential mesenchymal progenitor cells from trabecular bone. *Molecular Biotechnology*, 23, 37 - 49.
- Urban, J. (1994). The chondrocyte: A cell under pressure. *Br J Rheumatol* 33, 901-908.
- Urban, J. (2000). Present perspectives on cartilage and chondrocyte mechanobiology. *Biorheology*, 37, 185-190.
- Urban, M. R., Fermor, B., Lee, R. B., & Urban, J. P. G. (1998). Measurement of DNA in Intervertebral Disc and Other Autofluorescent Cartilages Using the Dye Hoechst 33258. *Analytical Biochemistry*, 262(1), 85-88.
- van Osch, G., van der Veen, S., & Verwoerd-Verhoef, H. (2001). In vitro redifferentiation of culture-expanded rabbit and human auricular chondrocytes for cartilage reconstruction. *Plastic and Reconstructive Surgery*, 107(2), 433-440.
- Villanueva, I., Gladem, S. K., Kessler, J., & Bryant, S. J. (2009). Dynamic loading stimulates chondrocyte biosynthesis when encapsulated in charged hydrogels prepared from poly(ethylene glycol) and chondroitin sulfate. *Matrix Biology*, 29(1), 51-62.
- Waldman, S. D., Couto, D. C., Gryn timer, M. D., Pilliar, R. M., & Kandel, R. A. (2007). Multi-axial Mechanical Stimulation of Tissue Engineered Cartilage. *European Cells and Materials*, 13, 66-75.
- Waldman, S. D., Spiteri, C. G., Gryn timer, M. D., Pilliar, R. M., & Kandel, R. A. (2003). Long-term intermittent shear deformation improves the quality of cartilaginous tissue formed in vitro. *Journal of Orthopaedic Research*, 21(4), 590-596.

- Waldman, S. D., Spiteri, C. G., Grynblas, M. D., Pilliar, R. M., & Kandel, R. A. (2004). Long-Term Intermittent Compressive Stimulation Improves the Composition and Mechanical Properties of Tissue-Engineered Cartilage. *Tissue Engineering*, 10(9-10), 1323-1331.
- Wang, J. H. C., & Thampatty, B. P. (2006). An introductory review of cell mechanobiology. *Biomechanics and Modeling in Mechanobiology*, 5, 1-16.
- Wilkins, R. J., Browning, J. A., & Urban, J. P. G. (2000). Chondrocyte regulation by mechanical load. *Biorheology*, 37(1), 67-74.
- Wimmer, M. A., Grad, S., Kaup, T., Hänni, M., Schneider, E., Gogolewski, S., & Alini, M. (2004). Tribology Approach to the Engineering and Study of Articular Cartilage. *Tissue Eng*, 10(9-10), 1436-1445.
- Wolf, A., Ackermann, B., & Steinmeyer, J. (2007). Collagen synthesis of articular cartilage explants in response to frequency of cyclic mechanical loading. *Cell and Tissue Research*, 327(1), 155-166.
- Wong, B. L., Bae, W. C., Chun, J., Gratz, K. R., Lotz, M., & Sah, R. L. (2008). Biomechanics of Cartilage Articulation: Effects of Lubrication and Degeneration on Shear Deformation. *Arthritis and Rheumatism*, 58(7), 2065-2074.
- Wong, M., Siegrist, M., & Cao, X. (1999). Cyclic compression of articular cartilage explants is associated with progressive consolidation and altered expression pattern of extracellular matrix proteins. *Matrix Biology*, 18(4), 391-399.
- Wooley, P. H., Michele, G. J., & Radin, E. L. (2005). The Structure and Function of Joints. In W. J. Koopman & L. W. Moreland (Eds.), *Arthritis & Allied Conditions* (15 ed., pp. 150-200). Philadelphia, Pennsylvania: Lippincott Williams and Wilkins.
- Wright, M., Jobanputra, P., Bavington, C., Salter, D. M., & Nuki, G. (1996). Effects of intermittent pressure-induced strain on the electrophysiology of cultured human chondrocytes: evidence for the presence of stretch-activated membrane ion channels. *Clinical Science*, 90(1), 61-71.
- Yang, F., & Elisseeff, J. (2006). Cartilage Tissue Engineering. In J. Bronzino (Ed.), *The Biomedical Engineering Handbook: Tissue Engineering and Artificial Organs*. Boca Raton: CRC Press.
- Yang, F., & Elisseeff, J. (2007). Cartilage Tissue Engineering. In J. P. Fisher, A. Mikos & J. Bronzino (Eds.), *Tissue Engineering* (pp. 1-11). Boca Raton: CRC Press.
- Yun, K., & Moon, H. T. (2008). Inducing Chondrogenic Differentiation in Injectable Hydrogels Embedded with Rabbit Chondrocytes and Growth Factor for Neocartilage Formation. *Journal of Bioscience and Bioengineering*, 105(2), 122-126.
- Yusoff, N. (2011). *Design and Development of an Advanced Bioreactor for Mechanical Cell Conditioning*. Unpublished Master's thesis, University of Malaya, Kuala Lumpur.
- Zeiter, S., der Werf, M., & Ito, K. (2009). The fate of bovine bone marrow stromal cells in hydrogels: a comparison to nucleus pulposus cells and articular chondrocytes. *Journal of Tissue Engineering and Regenerative Medicine*, 3(4), 310-320.